

JOB NUMBER:
SUBJECT: NEW HAVEN SWM-1'

Site Data:

Site Location: WASHINGTON COUNTY, HAGERSTOWN, MD

Type of Development: RESIDENTIAL

Rainfall Zone: — [(Western Rainfall Zone) P= 0.9" ←
(Eastern Rainfall Zone) P= 1.0"

Stream Use Designation: Class () Use: (Provide Extended Detention Time: T = Hr)

Proposed Site D.A. = 38 ac. ←

Off-Site D.A. = — ac.

Total D.A. to swm pond = 38 ac. ←

Total Impervious Area : (From TR-55)

1/8 Ac Lots : 38 ac. @ 65 % = 24.70 ac.

Total Impervious Area = 24.70 ←

JOB NUMBER:
SUBJECT: sum 1'

Water Quality Volume (WQv)

P = 0.9" (Western Rainfall Zone)

A = Drainage Area, (ac.) = 38

Total Impervious Area = 24.70

Rv = Volumetric Runoff Coefficient

I = % Total Impervious Area

$$I = \frac{(\text{Total Impervious Area})}{(A)} \times 100 \% = \frac{(24.7)}{(38)} \times 100 \% = 65 \%$$

$$Rv = 0.05 + 0.009 (I)$$

$$Rv = 0.05 + 0.009 (65) = 0.64$$

$$WQv = \frac{(P)(Rv)(A)}{12} = \frac{(0.9)(0.64)(38)}{12} = 1.82 \text{ ac-ft}$$

$$\text{Check Minimum Required} = \frac{(0.2")(A)}{12} = \frac{(0.2")(38)}{12} = 0.63 < 1.82 \text{ ac-ft}$$

Use WQv = 1.82 ac-ft ←

RUNOFF CURVE NUMBER COMPUTATION

Version 2.00

Project : NEW HAVEN

User: JS

Date: 12-30-99

County : WASHINGTON

State: MD

Checked: _____

Date: _____

Subtitle: Existing Conditions: SWM '1'

File: 1008A-E1

COVER DESCRIPTION	Hydrologic Soil Group			
	A	B	C	D
	Acres (CN)			
OTHER AGRICULTURAL LANDS				
Meadow -cont. grass (non grazed) ----	-	-	38(71)	-
Total Area (by Hydrologic Soil Group)			38	
			====	

TOTAL DRAINAGE AREA: 38 Acres

WEIGHTED CURVE NUMBER: 71*

* - Generated for use by GRAPHIC method

TIME OF CONCENTRATION AND TRAVEL TIME

Version 2.00

Project : NEW HAVEN

User: JS

Date: 12-30-99

County : WASHINGTON

State: MD

Checked: _____

Date: _____

Subtitle: Existing Conditions: SWM '1'

File: 1008A-E1

Flow Type	2 year rain	Length (ft)	Slope (ft/ft)	Surface code	n	Area (sq/ft)	Wp (ft)	Velocity (ft/sec)	Time (hr)
Sheet	3.0	100	0.02	F					0.246
Shallow Concent'd		1000	0.06	U					0.070

Time of Concentration = 0.32*

=====

--- Sheet Flow Surface Codes ---

A Smooth Surface

F Grass, Dense

--- Shallow Concentrated ---

B Fallow (No Res.)

G Grass, Burmuda

--- Surface Codes ---

C Cultivated < 20 % Res.

H Woods, Light

P Paved

D Cultivated > 20 % Res.

I Woods, Dense

U Unpaved

E Grass-Range, Short

J Range, Natural

* - Generated for use by GRAPHIC method

EXISTING

(PRE-DEVELOPED)
CONDITIONS

*****80-80 LIST OF INPUT DATA FOR TR-20 HYDROLOGY*****

JOB TR-20
 TITLE 001 NEW HAVEN
 TITLE Existing Conditions SWM Pond '1'
 6 RUNOFF 1 001 1 0.05937500 71 0.32
 ENDDATA
 7 INCREM 6 0.10
 7 COMPUT 7 001 001 2.5 1.0 2 2 01 1
 ENDCMP 1
 7 COMPUT 7 001 001 3.0 1.0 2 2 01 2
 ENDCMP 1
 7 COMPUT 7 001 001 4.8 1.0 2 2 01 10
 ENDCMP 1
 7 COMPUT 7 001 001 6.7 1.0 2 2 01 99
 ENDCMP 1
 ENDJOB 2

SUMMARY
File: TR20\1008A-EL.T20

0*****END OF 80-80 LIST*****

EXECUTIVE CONTROL OPERATION INCREM RECORD ID
+ MAIN TIME INCREMENT = .10 HOURS

EXECUTIVE CONTROL OPERATION COMPUT RECORD ID
+ FROM XSECTION 1 TO XSECTION 1
+ STARTING TIME = .00 RAIN DEPTH = 2.50 RAIN DURATION= 1.00 RAIN TABLE NO.= 2 ANT. MOIST. COND= 2
ALTERNATE NO.= 1 STORM NO.= 1 MAIN TIME INCREMENT = .10 HOURS

EXECUTIVE CONTROL OPERATION ENDCMP RECORD ID
+ COMPUTATIONS COMPLETED FOR PASS 1

EXECUTIVE CONTROL OPERATION COMPUT RECORD ID
+ FROM XSECTION 1 TO XSECTION 1
+ STARTING TIME = .00 RAIN DEPTH = 3.00 RAIN DURATION= 1.00 RAIN TABLE NO.= 2 ANT. MOIST. COND= 2
ALTERNATE NO.= 1 STORM NO.= 2 MAIN TIME INCREMENT = .10 HOURS

EXECUTIVE CONTROL OPERATION ENDCMP RECORD ID
+ COMPUTATIONS COMPLETED FOR PASS 2

EXECUTIVE CONTROL OPERATION COMPUT RECORD ID
+ FROM XSECTION 1 TO XSECTION 1
+ STARTING TIME = .00 RAIN DEPTH = 4.80 RAIN DURATION= 1.00 RAIN TABLE NO.= 2 ANT. MOIST. COND= 2
ALTERNATE NO.= 1 STORM NO.=10 MAIN TIME INCREMENT = .10 HOURS

EXECUTIVE CONTROL OPERATION ENDCMP RECORD ID
+ COMPUTATIONS COMPLETED FOR PASS 3

EXECUTIVE CONTROL OPERATION COMPUT RECORD ID
+ FROM XSECTION 1 TO XSECTION 1
+ STARTING TIME = .00 RAIN DEPTH = 6.70 RAIN DURATION= 1.00 RAIN TABLE NO.= 2 ANT. MOIST. COND= 2

ALTERNATE NO.= 1 STORM NO.=99 MAIN TIME INCREMENT = .10 HOURS

EXECUTIVE CONTROL OPERATION ENDCMP

RECORD ID

COMPUTATIONS COMPLETED FOR PASS 4

EXECUTIVE CONTROL OPERATION ENDJOB

RECORD ID

SUMMARY TABLE 1 - SELECTED RESULTS OF STANDARD AND EXECUTIVE CONTROL INSTRUCTIONS IN THE ORDER PERFORMED
 (A STAR (*) AFTER THE PEAK DISCHARGE TIME AND RATE (CFS) VALUES INDICATES A FLAT TOP HYDROGRAPH
 A QUESTION MARK (?) INDICATES A HYDROGRAPH WITH PEAK AS LAST POINT.)

SECTION/ STRUCTURE ID	STANDARD CONTROL OPERATION	DRAINAGE AREA (SQ MI)	RAIN TABLE #	ANTEC MOIST COND	MAIN TIME INCREM (HR)	PRECIPITATION			RUNOFF AMOUNT (IN)	PEAK DISCHARGE				
						BEGIN (HR)	AMOUNT (IN)	DURATION (HR)		ELEVATION (FT)	TIME (HR)	RATE (CFS)	RATE (CSM)	
ALTERNATE	1	STORM	1											
+ XSECTION	1	RUNOFF	.06	2	2	.10	.0	2.50	24.00	.49	---	12.13	16.43	276.7
ALTERNATE	1	STORM	2											
+ XSECTION	1	RUNOFF	.06	2	2	.10	.0	3.00	24.00	.76	---	12.12	27.68	466.2
ALTERNATE	1	STORM	10											
+ XSECTION	1	RUNOFF	.06	2	2	.10	.0	4.80	24.00	1.96	---	12.10	77.53	1305.8
ALTERNATE	1	STORM	99											
+ XSECTION	1	RUNOFF	.06	2	2	.10	.0	6.70	24.00	3.47	---	12.10	138.28	2328.9

SUMMARY TABLE 3 - DISCHARGE (CFS) AT XSECTIONS AND STRUCTURES FOR ALL STORMS AND ALTERNATES

XSECTION/ STRUCTURE ID	DRAINAGE AREA (SQ MI)	STORM NUMBERS.....			
		1	2	10	99
0 XSECTION 1	.06				
+ ALTERNATE 1		16.43	27.68	77.53	138.28
		↑ Q_1	↑ Q_2	↑ Q_{10}	↑ Q_{100}

← Q_{PRE}

SWM '1'

END OF 1 JOBS IN THIS RUN

GRAPHICAL PEAK DISCHARGE METHOD

Version 2.00

Project : NEW HAVEN

User: JS

Date: 12-30-99

County : WASHINGTON

State: MD

Checked: _____

Date: _____

Subtitle: Existing Conditions: SWM '1'

File: 1008A-E1

Data: Drainage Area : 38 * Acres
 Runoff Curve Number : 71 *
 Time of Concentration: 0.32 * Hours
 Rainfall Type : II
 Pond and Swamp Area : NONE

Storm Number	1	2	3	4	5	6	7
Frequency (yrs)	1	2	5	10	25	50	100
24-Hr Rainfall (in)	2.5	3	3.9	4.8	5.1	6	6.7
Ia/P Ratio	0.33	0.27	0.21	0.17	0.16	0.14	0.12
Runoff (in)	0.49	0.76	1.33	1.97	2.19	2.90	3.47
Unit Peak Discharge (cfs/acre/in)	0.825	0.890	0.940	0.971	0.979	0.998	1.009
Pond and Swamp Factor 0.0% Ponds Used	1.00	1.00	1.00	1.00	1.00	1.00	1.00
Peak Discharge (cfs)	15	26	47	73	82	110	133

* - Value(s) provided from TR-55 system routines

RUNOFF CURVE NUMBER COMPUTATION

Version 2.00

Project : NEW HAVEN

User: JS

Date: 12-30-99

County : WASHINGTON

State: MD

Checked: _____

Date: _____

Subtitle: Proposed Conditions: SWM '1'

File: 1008A-P1

COVER DESCRIPTION	Hydrologic Soil Group			
	A	B	C	D
	Acres (CN)			
FULLY DEVELOPED URBAN AREAS (Veg Estab.)				
Residential districts				
(by average lot size)				
1/8 acre (town houses)	65	-	38(90)	-
Total Area (by Hydrologic Soil Group)			38	
			====	

TOTAL DRAINAGE AREA: 38 Acres

WEIGHTED CURVE NUMBER: 90*

* - Generated for use by GRAPHIC method

TIME OF CONCENTRATION AND TRAVEL TIME

Version 2.00

Project : NEW HAVEN

User: JS

Date: 12-30-99

County : WASHINGTON

State: MD

Checked: _____

Date: _____

Subtitle: Proposed Conditions: SWM '1'

File: 1008A-P1

Flow Type	2 year rain	Length (ft)	Slope (ft/ft)	Surface code	n	Area (sq/ft)	Wp (ft)	Velocity (ft/sec)	Time (hr)
Sheet	3.0	50	0.02	E					0.097
Shallow Concent'd		200	0.02	P					0.019
Open Channel		2000					8		0.069

Time of Concentration = 0.19*

=====

--- Sheet Flow Surface Codes ---

A Smooth Surface
 B Fallow (No Res.)
 C Cultivated < 20 % Res.
 D Cultivated > 20 % Res.
 E Grass-Range, Short

F Grass, Dense
 G Grass, Bermuda
 H Woods, Light
 I Woods, Dense
 J Range, Natural

--- Shallow Concentrated ---
 --- Surface Codes ---
 P Paved
 U Unpaved

* - Generated for use by GRAPHIC method

GRAPHICAL PEAK DISCHARGE METHOD

Version 2.00

Project : NEW HAVEN

User: JS

Date: 12-30-99

County : WASHINGTON

State: MD

Checked: _____

Date: _____

Subtitle: Proposed Conditions: SWM '1'

File: 1008A-P1

Data: Drainage Area : 38 * Acres
 Runoff Curve Number : 90 *
 Time of Concentration: 0.19 * Hours
 Rainfall Type : II
 Pond and Swamp Area : NONE

Storm Number	1	2	3	4	5	6	7
Frequency (yrs)	1	2	5	10	25	50	100
24-Hr Rainfall (in)	2.5	3	3.9	4.8	5.1	6	6.7
Ia/P Ratio	0.09	0.07	0.06	0.05	0.04	0.04	0.03
Used	0.10	0.10	0.10	0.10	0.10	0.10	0.10
Runoff (in)	1.53	1.98	2.82	3.68	3.97	4.85	5.53
Unit Peak Discharge (cfs/acre/in)	1.275	1.275	1.275	1.275	1.275	1.275	1.275
Pond and Swamp Factor 0.0% Ponds Used	1.00	1.00	1.00	1.00	1.00	1.00	1.00
Peak Discharge (cfs)	74	96	137	178	192	235	268

* - Value(s) provided from TR-55 system routines

JOB NUMBER:
SUBJECT: Swm '1'

Pond Pretreatment \ Sedimentation Forebay

Size Forebay to Treat 0.10" per total Impervious Area.

Total Impervious Area = 24.7 ac.

$$V_{\text{Req'd.}} = (24.7 \text{ ac.}) (0.10") (1' / 12") = 0.21 \text{ ac-ft}$$

$$V_{\text{Provided}} = \underline{\underline{0.30}} \text{ ac-ft} \quad \leftarrow$$

" Forebay Storage Volume "

Elev.	Area (ft ²)	Average Area (ft ²)	Depth (ft)	Volume (ft ³)	Σ Volume (ft ³)	Σ Volume (ac-ft)
600	5500				0	0
		6600	2'	13200		
602	7700				13200	0.30

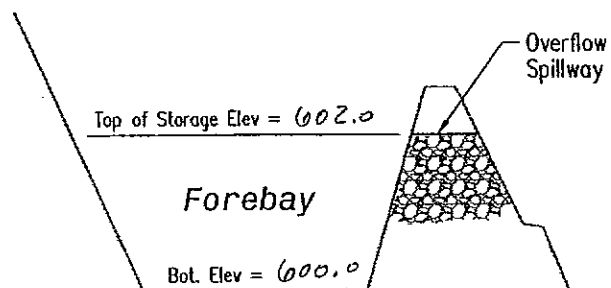

RODGERS CONSULTING, INC.
 19847 Century Blvd. (Suite 200)
 Germantown, MD 20874
 301-948-4700

USER:
 DATE: 4/20/2006
 CHECKED BY:
 JOB NO.:
 FILE NAME:

SWM POND '1'
 STAGE/STORAGE TABULATION
 PLAN SCALE 1in. = 1

ELEV.	AREA SQ. IN.	AREA SQ. FT.	AVG. AREA SQ. FT.	ELEV. DIFF. FT.	INCR. VOLUME CU. FT.	TOTAL VOLUME CU. FT.	TOTAL VOLUME AC. FT.
593	3000	3000				0	0
			3650	1.0	3650		
594	4300	4300				3650	0.0838
			5500	2.0	11000		
596	6700	6700				14650	0.3363
			7850	2.0	15700		
598	9000	9000				30350	0.6967
			10900	0.10	1090		
598.1	12800	12800				31440	0.7218
			14400	0.90	12960		
<u>599</u>	16000	16000				44400	1.0193
			16250	0.15	2437		
599.15	16500	16500				46837	1.0752
			20250	0.85	17213		0.0559
600	24000	24000				64050	1.4704
			25500	1.50	38250		0.4511
601.5	27000	27000				102300	2.3485
			27500	0.15	4125		1.3292
601.65	28000	28000				106425	2.4432
			29000	0.15	4350		1.4239
601.8	30000	30000				110775	2.5430
			34500	0.20	6900		1.5237
602	39000	39000				117675	2.7014
			41250	1.00	41250		1.6821
603	43500	43500				158925	3.6484
			45750	1.00	45750		2.6291
604	48000	48000				204675	4.6987
			50750	1.00	50750		3.6794
605	53500	53500				255425	5.8638
			56250	1.00	56250		4.8445
606	59000	59000				311675	7.1551
			61000	1.00	61000		6.1358
607	63000	63000				372675	8.5554
			65000	1.0	65000		7.5361
608	67000	67000				437675	10.0476
			#N/A	#N/A	#N/A		9.0283
0	0	0				#N/A	#N/A
			0	0.0	0		
0	0	0				#N/A	#N/A
			0	0.0	0		
0	0	0				#N/A	#N/A

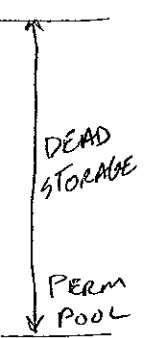

0.00	593
0.08	594
0.34	596
0.70	598
0.72	598.1
1.02	599
1.08	599.15
1.47	600
2.35	601.5
2.44	601.65
2.54	601.8
2.70	602
3.65	603
4.70	604
5.86	605
7.16	606
8.56	607
10.05	608
#N/A	0
#N/A	0
#N/A	0

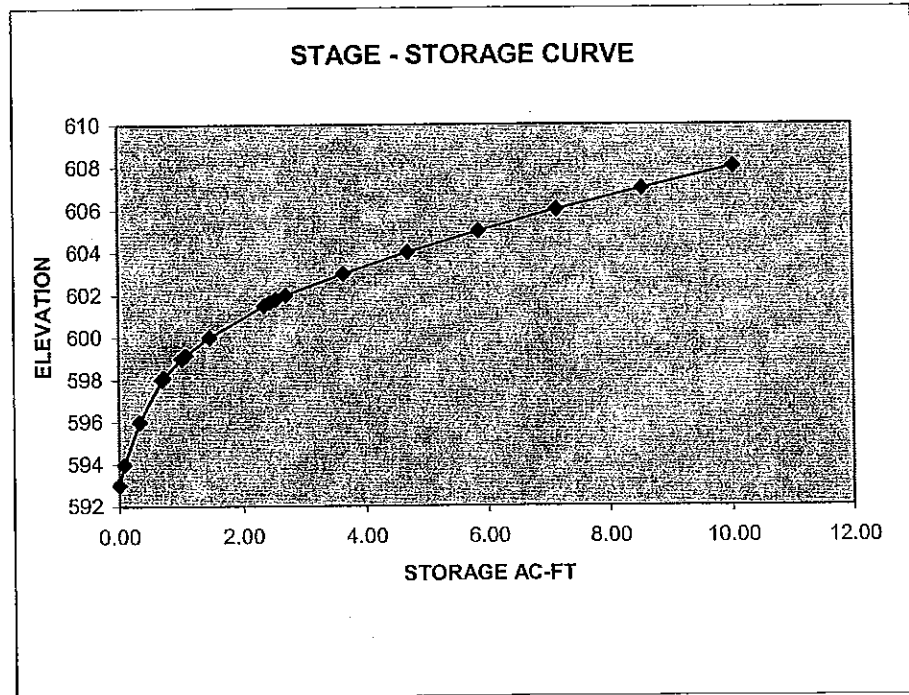

Swam - 1'

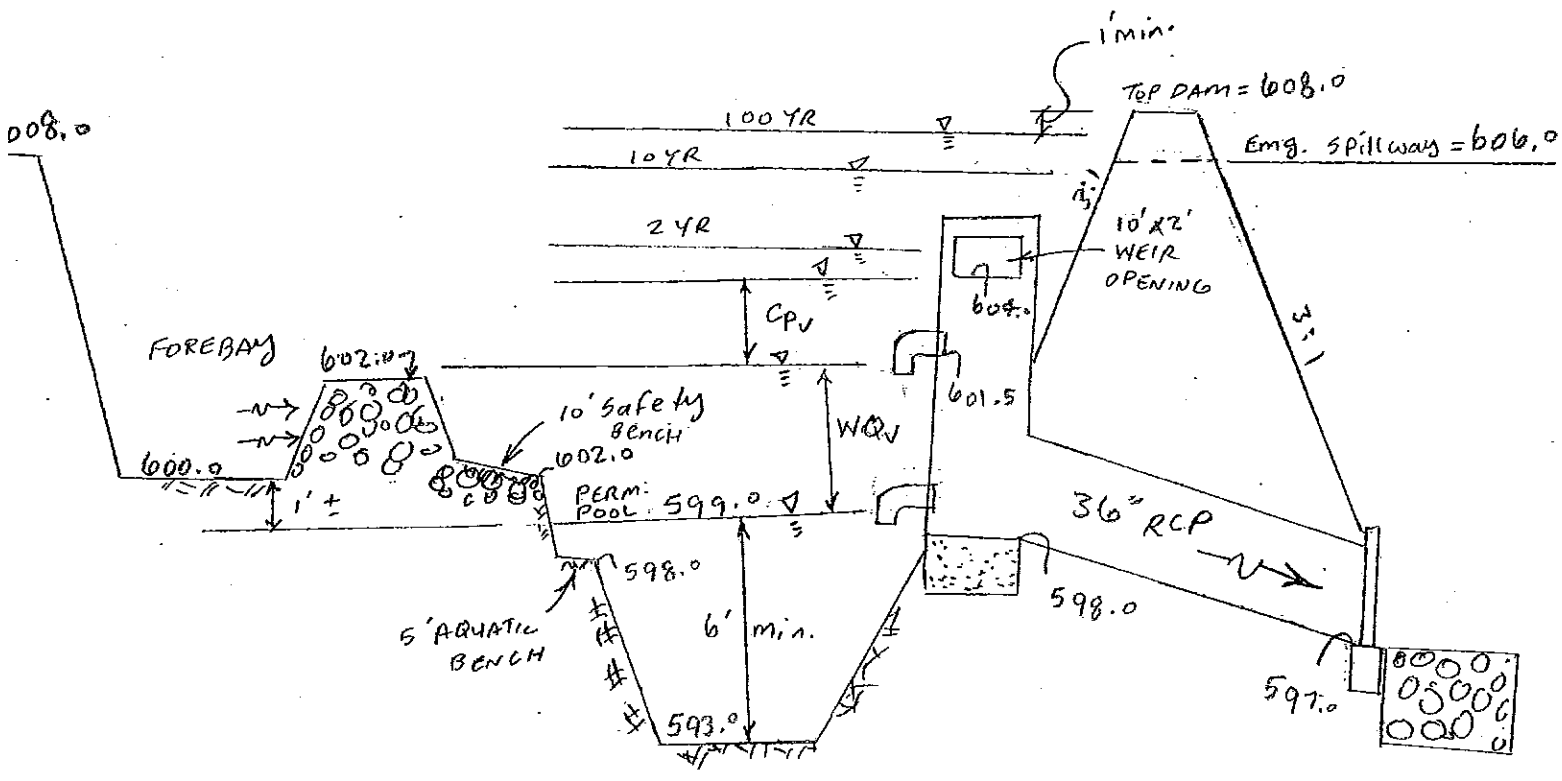

Storage-Elevation-Discharge Data

JOB NUMBER: 1008A
 SUBJECT: NEW HAVEN
 Sum - 1'

N:\HYDRAUL\TR20\1008A-Pl.720

$A = 7.07 \text{ ft}^2$
 $K_m = 1$
 $K_p = \frac{29 \text{ ft}^3}{\text{R}^4 \text{ S}}$
 $R = 0/4$

POND WATER SURFACE ELEV.	3.5" ϕ Low-Stage 24 Hr ED (1-yr) (WQV-ED)				3.5" ϕ MID-Stage CPV (1-yr) (CPV-ED)				High-Stage				BARREL				DISCHARGE Q (cfs)	STORAGE VOLUME (Ac-Ft)						
	Weir		Orifice		Weir		Orifice		Weir		Orifice		Inlet Control		Outlet Control				Emergency Spillway					
	H	Q	H	Q	H	Q	H	Q	H	Q	H	Q	H	Q	H	Q								
599.6																								
599.9																							0	0
599.15	0.15'	0.08'																					0.08	0.0559
600																							0.31	0.4511
601.5																							0.39	1.3292
601.65																							0.62	1.4239
601.80																							0.68	1.5237
602																							0.77	1.6821
603																							1.06	2.6291
604																							1.27	3.6794
605																							32.44	4.8445
606																							86.8	6.1358
607																							117.2	7.5361
608																							182.2	9.0283

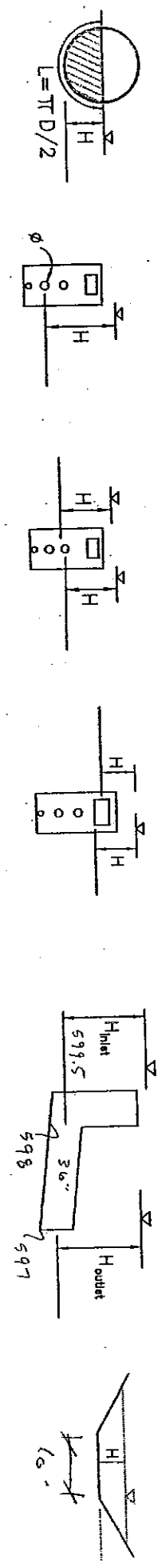

*****80-80 LIST OF INPUT DATA FOR TR-20 HYDROLOGY*****

```

JOB TR-20                FULLPRINT
TITLE 001                NEW HAVEN                File:TR20\1008A-Pl.T20
TITLE 002                SWM POND '1'
3 STRUCT                01
8                        599.00                0.00                0.000
8                        599.15                0.08                0.0559
8                        600.00                0.31                0.4511
8                        601.50                0.39                1.3292
8                        601.65                0.62                1.4239
8                        601.80                0.68                1.5237
8                        602.00                0.77                1.6821
8                        603.00                1.06                2.6291
8                        604.00                1.27                3.6794
8                        605.00                32.44                4.8445
8                        606.00                86.80                6.1358
8                        607.00                117.20               7.5361
8                        608.00                182.20               9.0283
9 ENDTBL
6 RUNOFF 1 01 4 0.05937500 90 0.19 1 1
6 RESVOR 2 01 4 5 599.0 0 1 1 1 1
  ENDDATA
7 INCREM 6 0.1
7 COMPUT 7 01 01 0.0 2.5 1.02 2 01
  ENDCMP 1
7 COMPUT 7 01 01 0.0 3.0 1.02 2 02
  ENDCMP 1
7 COMPUT 7 01 01 0.0 4.8 1.02 2 10
  ENDCMP 1
7 COMPUT 7 01 01 0.0 6.7 1.02 2 99
  ENDCMP 1
  ENDJOB 2

```

0*****END OF 80-80 LIST*****

EXECUTIVE CONTROL OPERATION INCREM

RECORD ID

MAIN TIME INCREMENT = .10 HOURS

EXECUTIVE CONTROL OPERATION COMPUT

RECORD ID

FROM STRUCTURE 1
TO STRUCTURE 1

STARTING TIME = .00 RAIN DEPTH = 2.50 RAIN DURATION= 1.00 RAIN TABLE NO.= 2 ANT. MOIST. COND= 2
ALTERNATE NO.= 0 STORM NO.= 1 MAIN TIME INCREMENT = .10 HOURS

OPERATION RUNOFF STRUCTURE 1

OUTPUT HYDROGRAPH= 4
AREA= .06 SQ MI INPUT RUNOFF CURVE= 90. TIME OF CONCENTRATION= .19 HOURS
INTERNAL HYDROGRAPH TIME INCREMENT= .0253 HOURS

PEAK TIME(HRS)	PEAK DISCHARGE(CFS)	PEAK ELEVATION(FEET)
12.01	71.82	(RUNOFF)
23.65	1.03	(RUNOFF)

RUNOFF VOLUME ABOVE BASEFLOW = 1.54 WATERSHED INCHES, 58.83 CFS-HRS, 4.86 ACRE-FEET; BASEFLOW = .00 CFS

OPERATION RESVOR STRUCTURE 1

INPUT HYDROGRAPH= 4 OUTPUT HYDROGRAPH= 5
SURFACE ELEVATION= 599.00

*** WARNING-NO PEAK FOUND, MAXIMUM DISCHARGE = 1.26 CFS.

PEAK TIME(HRS)	PEAK DISCHARGE(CFS)	PEAK ELEVATION(FEET)
19.80	1.26	603.97

TIME(HRS)	FIRST HYDROGRAPH POINT =	.00 HOURS	TIME INCREMENT =	.10 HOURS	DRAINAGE AREA =	.06 SQ.MI.
7.00	DISCHG	.00	.00	.01	.01	.02
7.00	ELEV	599.00	599.00	599.01	599.01	599.03
8.00	DISCHG	.02	.02	.03	.03	.06
8.00	ELEV	599.03	599.04	599.05	599.06	599.10
9.00	DISCHG	.06	.07	.08	.09	.10
9.00	ELEV	599.11	599.13	599.14	599.15	599.23
10.00	DISCHG	.11	.11	.12	.13	.17
10.00	ELEV	599.25	599.26	599.28	599.30	599.48
11.00	DISCHG	.18	.20	.21	.24	.36
11.00	ELEV	599.53	599.58	599.63	599.76	601.02
12.00	DISCHG	.70	.89	1.00	1.08	1.14
12.00	ELEV	601.84	602.43	602.81	603.11	603.40
13.00	DISCHG	1.15	1.16	1.17	1.18	1.20
13.00	ELEV	603.44	603.48	603.51	603.57	603.67
14.00	DISCHG	1.21	1.21	1.21	1.22	1.23
14.00	ELEV	603.69	603.71	603.72	603.75	603.80
15.00	DISCHG	1.23	1.23	1.23	1.24	1.24
15.00	ELEV	603.81	603.82	603.83	603.84	603.87
16.00	DISCHG	1.24	1.25	1.25	1.25	1.25

TR20 XEQ 04-20-06 16:02
REV PC 09/83(.2)

NEW HAVEN
SWM POND '1'

File:TR20\1008A-P1.T20

JOB 1 PASS 1
PAGE 2

16.00	ELEV	603.88	603.88	603.89	603.90	603.90	603.91	603.91	603.92	603.92	603.92
17.00	DISCHG	1.25	1.26	1.26	1.26	1.26	1.26	1.26	1.26	1.26	1.26
17.00	ELEV	603.93	603.93	603.93	603.94	603.94	603.94	603.95	603.95	603.95	603.96
18.00	DISCHG	1.26	1.26	1.26	1.26	1.26	1.26	1.26	1.26	1.26	1.26
18.00	ELEV	603.96	603.96	603.96	603.96	603.96	603.96	603.96	603.96	603.96	603.96
19.00	DISCHG	1.26	1.26	1.26	1.26	1.26	1.26	1.26	1.26	1.26	1.26
19.00	ELEV	603.97	603.97	603.97	603.97	603.97	603.97	603.97	603.97	603.97	603.97
20.00	DISCHG	1.26	1.26	1.26	1.26	1.26	1.26	1.26	1.26	1.26	1.26
20.00	ELEV	603.97	603.97	603.97	603.96	603.96	603.96	603.96	603.96	603.95	603.95
21.00	DISCHG	1.26	1.26	1.26	1.26	1.26	1.26	1.26	1.26	1.26	1.26
21.00	ELEV	603.95	603.95	603.95	603.94	603.94	603.94	603.94	603.94	603.94	603.93
22.00	DISCHG	1.26	1.26	1.25	1.25	1.25	1.25	1.25	1.25	1.25	1.25
22.00	ELEV	603.93	603.93	603.93	603.93	603.92	603.92	603.92	603.92	603.92	603.92
23.00	DISCHG	1.25	1.25	1.25	1.25	1.25	1.25	1.25	1.25	1.25	1.25
23.00	ELEV	603.91	603.91	603.91	603.91	603.91	603.90	603.90	603.90	603.90	603.90
24.00	DISCHG	1.25	1.25	1.24	1.24	1.24	1.24	1.24	1.23	1.23	1.23
24.00	ELEV	603.89	603.89	603.88	603.87	603.86	603.85	603.84	603.83	603.82	603.81
25.00	DISCHG	1.23	1.23	1.22	1.22	1.22	1.22	1.22	1.21	1.21	1.21
25.00	ELEV	603.80	603.79	603.78	603.77	603.77	603.76	603.75	603.74	603.73	603.72
26.00	DISCHG	1.21	1.21	1.20	1.20	1.20	1.20	1.20	1.19	1.19	1.19
26.00	ELEV	603.71	603.70	603.69	603.68	603.67	603.66	603.65	603.64	603.63	603.62
27.00	DISCHG	1.19	1.19	1.18	1.18	1.18	1.18	1.18	1.18	1.17	1.17
27.00	ELEV	603.61	603.60	603.59	603.59	603.58	603.57	603.56	603.55	603.54	603.53
28.00	DISCHG	1.17	1.17	1.17	1.16	1.16	1.16	1.16	1.16	1.15	1.15
28.00	ELEV	603.52	603.51	603.50	603.49	603.48	603.47	603.47	603.46	603.45	603.44
29.00	DISCHG	1.15	1.15	1.15	1.14	1.14	1.14	1.14	1.14	1.14	1.13
29.00	ELEV	603.43	603.42	603.41	603.40	603.39	603.38	603.38	603.37	603.36	603.35

RUNOFF VOLUME ABOVE BASEFLOW = .58 WATERSHED INCHES, 22.33 CFS-HRS, 1.85 ACRE-FEET; BASEFLOW = .00 CFS

EXECUTIVE CONTROL OPERATION ENDCMP

COMPUTATIONS COMPLETED FOR PASS 1

RECORD ID

EXECUTIVE CONTROL OPERATION COMPUT

RECORD ID

FROM STRUCTURE 1

TO STRUCTURE 1

STARTING TIME = .00 RAIN DEPTH = 3.00 RAIN DURATION= 1.00 RAIN TABLE NO.= 2 ANT. MOIST. COND= 2
ALTERNATE NO.= 0 STORM NO.= 2 MAIN TIME INCREMENT = .10 HOURS

OPERATION RUNOFF STRUCTURE 1

OUTPUT HYDROGRAPH= 4

AREA= .06 SQ MI INPUT RUNOFF CURVE= 90. TIME OF CONCENTRATION= .19 HOURS

INTERNAL HYDROGRAPH TIME INCREMENT= .0253 HOURS

PEAK TIME(HRS)	PEAK DISCHARGE(CFS)	PEAK ELEVATION(FEET)
12.01	92.28	(RUNOFF)
23.65	1.27	(RUNOFF)

RUNOFF VOLUME ABOVE BASEFLOW = 1.99 WATERSHED INCHES, 76.24 CFS-HRS, 6.30 ACRE-FEET; BASEFLOW = .00 CFS

OPERATION RESVOR STRUCTURE 1

INPUT HYDROGRAPH= 4 OUTPUT HYDROGRAPH= 5

SURFACE ELEVATION= 599.00

PEAK TIME(HRS)	PEAK DISCHARGE(CFS)	PEAK ELEVATION(FEET)
13.07	7.17	604.19

TIME(HRS)	FIRST HYDROGRAPH POINT =	.00 HOURS	TIME INCREMENT =	.10 HOURS	DRAINAGE AREA =	.06 SQ.MI.
6.00	DISCHG	.00	.00	.00	.01	.01
6.00	ELEV	599.00	599.00	599.00	599.01	599.01
7.00	DISCHG	.02	.02	.03	.03	.04
7.00	ELEV	599.03	599.04	599.05	599.06	599.07
8.00	DISCHG	.06	.06	.07	.08	.09
8.00	ELEV	599.10	599.11	599.12	599.14	599.15
9.00	DISCHG	.10	.11	.11	.12	.13
9.00	ELEV	599.23	599.24	599.26	599.30	599.32
10.00	DISCHG	.16	.16	.17	.19	.20
10.00	ELEV	599.43	599.46	599.49	599.55	599.59
11.00	DISCHG	.27	.29	.31	.32	.33
11.00	ELEV	599.85	599.92	599.99	600.14	600.22
12.00	DISCHG	.91	1.10	1.19	1.24	1.26
12.00	ELEV	602.48	603.18	603.62	603.84	603.97
13.00	DISCHG	7.15	7.17	7.07	6.90	6.70
13.00	ELEV	604.19	604.19	604.18	604.17	604.17
14.00	DISCHG	5.18	4.96	4.74	4.54	4.35
14.00	ELEV	604.13	604.12	604.11	604.10	604.10
15.00	DISCHG	3.36	3.27	3.19	3.13	3.05
15.00	ELEV	604.07	604.06	604.06	604.06	604.06
16.00	DISCHG	2.64	2.61	2.58	2.56	2.55
16.00	ELEV	604.04	604.04	604.04	604.04	604.04
17.00	DISCHG	2.29	2.25	2.21	2.19	2.16
17.00	ELEV	604.03	604.03	604.03	604.03	604.03

18.00	DISCHG	2.02	1.96	1.90	1.85	1.82	1.79	1.76	1.75	1.73	1.72
18.00	ELEV	604.02	604.02	604.02	604.02	604.02	604.02	604.02	604.02	604.01	604.01
19.00	DISCHG	1.71	1.70	1.70	1.69	1.69	1.68	1.68	1.68	1.68	1.65
19.00	ELEV	604.01	604.01	604.01	604.01	604.01	604.01	604.01	604.01	604.01	604.01
20.00	DISCHG	1.59	1.53	1.48	1.44	1.40	1.37	1.35	1.33	1.32	1.31
20.00	ELEV	604.01	604.01	604.01	604.01	604.00	604.00	604.00	604.00	604.00	604.00
21.00	DISCHG	1.30	1.29	1.28	1.28	1.27	1.27	1.27	1.27	1.27	1.27
21.00	ELEV	604.00	604.00	604.00	604.00	604.00	604.00	604.00	604.00	604.00	604.00
22.00	DISCHG	1.27	1.27	1.27	1.27	1.27	1.27	1.27	1.27	1.27	1.27
22.00	ELEV	604.00	604.00	604.00	604.00	604.00	604.00	604.00	604.00	604.00	604.00
23.00	DISCHG	1.27	1.27	1.27	1.27	1.27	1.27	1.27	1.27	1.27	1.27
23.00	ELEV	604.00	604.00	604.00	604.00	604.00	604.00	604.00	604.00	604.00	604.00
24.00	DISCHG	1.27	1.27	1.27	1.26	1.26	1.26	1.26	1.26	1.25	1.25
24.00	ELEV	604.00	603.99	603.98	603.98	603.97	603.96	603.95	603.94	603.93	603.92
25.00	DISCHG	1.25	1.25	1.25	1.24	1.24	1.24	1.24	1.24	1.23	1.23
25.00	ELEV	603.91	603.90	603.89	603.88	603.87	603.86	603.85	603.84	603.83	603.82
26.00	DISCHG	1.23	1.23	1.23	1.22	1.22	1.22	1.22	1.22	1.21	1.21
26.00	ELEV	603.81	603.80	603.79	603.78	603.77	603.76	603.75	603.74	603.73	603.72
27.00	DISCHG	1.21	1.21	1.21	1.20	1.20	1.20	1.20	1.20	1.19	1.19
27.00	ELEV	603.71	603.70	603.69	603.68	603.67	603.67	603.66	603.65	603.64	603.63
28.00	DISCHG	1.19	1.19	1.19	1.18	1.18	1.18	1.18	1.18	1.17	1.17
28.00	ELEV	603.62	603.61	603.60	603.59	603.58	603.57	603.56	603.55	603.54	603.53
29.00	DISCHG	1.17	1.17	1.17	1.16	1.16	1.16	1.16	1.16	1.15	1.15
29.00	ELEV	603.53	603.52	603.51	603.50	603.49	603.48	603.47	603.46	603.45	603.44

RUNOFF VOLUME ABOVE BASEFLOW = 1.00 WATERSHED INCHES, 38.49 CFS-HRS, 3.18 ACRE-FEET; BASEFLOW = .00 CFS

EXECUTIVE CONTROL OPERATION ENDCMP

COMPUTATIONS COMPLETED FOR PASS 2

RECORD ID

EXECUTIVE CONTROL OPERATION COMPUT

RECORD ID

FROM STRUCTURE 1 TO STRUCTURE 1
STARTING TIME = .00 RAIN DEPTH = 4.80 RAIN DURATION= 1.00 RAIN TABLE NO.= 2 AMT. MOIST. COND= 2
ALTERNATE NO.= 0 STORM NO.=10 MAIN TIME INCREMENT = .10 HOURS

OPERATION RUNOFF STRUCTURE 1

OUTPUT HYDROGRAPH= 4
AREA= .06 SQ MI INPUT RUNOFF CURVE= 90. TIME OF CONCENTRATION= .19 HOURS
INTERNAL HYDROGRAPH TIME INCREMENT= .0253 HOURS

PEAK TIME(HRS)	PEAK DISCHARGE(CFS)	PEAK ELEVATION(FEET)
12.01	166.34	(RUNOFF)
23.65	2.13	(RUNOFF)

RUNOFF VOLUME ABOVE BASEFLOW = 3.69 WATERSHED INCHES, 141.54 CFS-HRS, 11.70 ACRE-FEET; BASEFLOW = .00 CFS

OPERATION RESVOR STRUCTURE 1

INPUT HYDROGRAPH= 4 OUTPUT HYDROGRAPH= 5
SURFACE ELEVATION= 599.00

PEAK TIME(HRS)	PEAK DISCHARGE(CFS)	PEAK ELEVATION(FEET)
12.22	67.14	605.64

TIME(HRS)	FIRST HYDROGRAPH POINT = .00 HOURS	TIME INCREMENT = .10 HOURS	DRAINAGE AREA = .06 SQ.MI.
4.00	DISCHG .00 .00 .00 .00 .00 .00 .01 .01 .01 .02		
4.00	ELEV 599.00 599.00 599.00 599.00 599.00 599.00 599.01 599.02 599.02 599.03		
5.00	DISCHG .02 .02 .03 .03 .04 .04 .05 .06 .06 .07		
5.00	ELEV 599.04 599.05 599.05 599.06 599.07 599.08 599.09 599.10 599.12 599.13		
6.00	DISCHG .07 .08 .08 .09 .09 .10 .10 .11 .11 .12		
6.00	ELEV 599.14 599.15 599.17 599.18 599.20 599.21 599.23 599.25 599.26 599.28		
7.00	DISCHG .12 .13 .13 .14 .14 .15 .15 .16 .17 .17		
7.00	ELEV 599.30 599.32 599.34 599.36 599.38 599.40 599.43 599.45 599.47 599.49		
8.00	DISCHG .18 .19 .19 .20 .21 .22 .23 .24 .25 .26		
8.00	ELEV 599.52 599.54 599.57 599.60 599.63 599.67 599.71 599.74 599.78 599.82		
9.00	DISCHG .27 .28 .30 .31 .31 .32 .32 .33 .33 .34		
9.00	ELEV 599.86 599.91 599.95 600.00 600.04 600.08 600.12 600.17 600.22 600.26		
10.00	DISCHG .33 .33 .33 .34 .34 .35 .35 .36 .36 .36		
10.00	ELEV 600.31 600.37 600.42 600.48 600.54 600.61 600.69 600.77 600.87 600.97		
11.00	DISCHG .37 .37 .38 .39 .42 .48 .57 .67 1.01 1.19		
11.00	ELEV 601.09 601.21 601.35 601.50 601.65 601.80 602.01 602.34 602.84 603.61		
12.00	DISCHG 20.24 52.87 66.58 61.96 53.20 44.45 37.15 31.72 28.65 25.91		
12.00	ELEV 604.61 605.38 605.63 605.54 605.38 605.22 605.09 604.98 604.88 604.79		
13.00	DISCHG 23.42 21.23 19.27 17.56 16.06 14.74 13.58 12.53 11.59 10.78		
13.00	ELEV 604.71 604.64 604.58 604.52 604.47 604.43 604.39 604.36 604.33 604.30		
14.00	DISCHG 10.06 9.43 8.87 8.37 7.91 7.48 7.09 6.72 6.38 6.09		
14.00	ELEV 604.28 604.26 604.24 604.23 604.21 604.20 604.19 604.17 604.16 604.15		
15.00	DISCHG 5.85 5.66 5.51 5.38 5.24 5.07 4.90 4.77 4.65 4.56		
15.00	ELEV 604.15 604.14 604.14 604.13 604.13 604.12 604.12 604.11 604.11 604.11		

16.00	DISCHG	4.49	4.43	4.39	4.35	4.32	4.30	4.26	4.17	4.06	3.96
16.00	ELEV	604.10	604.10	604.10	604.10	604.10	604.10	604.10	604.09	604.09	604.09
17.00	DISCHG	3.87	3.80	3.74	3.69	3.66	3.63	3.60	3.59	3.57	3.51
17.00	ELEV	604.08	604.08	604.08	604.08	604.08	604.08	604.07	604.07	604.07	604.07
18.00	DISCHG	3.41	3.30	3.21	3.13	3.07	3.02	2.98	2.94	2.92	2.90
18.00	ELEV	604.07	604.07	604.06	604.06	604.06	604.06	604.05	604.05	604.05	604.05
19.00	DISCHG	2.88	2.87	2.86	2.85	2.84	2.84	2.83	2.83	2.82	2.78
19.00	ELEV	604.05	604.05	604.05	604.05	604.05	604.05	604.05	604.05	604.05	604.05
20.00	DISCHG	2.68	2.58	2.49	2.42	2.36	2.31	2.27	2.24	2.21	2.19
20.00	ELEV	604.05	604.04	604.04	604.04	604.03	604.03	604.03	604.03	604.03	604.03
21.00	DISCHG	2.18	2.17	2.16	2.15	2.14	2.14	2.13	2.13	2.13	2.13
21.00	ELEV	604.03	604.03	604.03	604.03	604.03	604.03	604.03	604.03	604.03	604.03
22.00	DISCHG	2.12	2.12	2.12	2.12	2.12	2.12	2.12	2.12	2.12	2.12
22.00	ELEV	604.03	604.03	604.03	604.03	604.03	604.03	604.03	604.03	604.03	604.03
23.00	DISCHG	2.12	2.12	2.12	2.12	2.12	2.12	2.12	2.12	2.11	2.07
23.00	ELEV	604.03	604.03	604.03	604.03	604.03	604.03	604.03	604.03	604.03	604.03
24.00	DISCHG	1.98	1.83	1.60	1.32	1.27	1.27	1.26	1.26	1.26	1.26
24.00	ELEV	604.02	604.02	604.01	604.00	603.99	603.98	603.97	603.96	603.95	603.94
25.00	DISCHG	1.26	1.25	1.25	1.25	1.25	1.25	1.24	1.24	1.24	1.24
25.00	ELEV	603.93	603.92	603.91	603.90	603.89	603.88	603.87	603.86	603.85	603.84
26.00	DISCHG	1.24	1.23	1.23	1.23	1.23	1.23	1.22	1.22	1.22	1.22
26.00	ELEV	603.83	603.82	603.82	603.81	603.80	603.79	603.78	603.77	603.76	603.75
27.00	DISCHG	1.22	1.21	1.21	1.21	1.21	1.21	1.20	1.20	1.20	1.20
27.00	ELEV	603.74	603.73	603.72	603.71	603.70	603.69	603.68	603.67	603.66	603.65
28.00	DISCHG	1.20	1.19	1.19	1.19	1.19	1.19	1.18	1.18	1.18	1.18
28.00	ELEV	603.64	603.63	603.62	603.62	603.61	603.60	603.59	603.58	603.57	603.56
29.00	DISCHG	1.18	1.17	1.17	1.17	1.17	1.17	1.16	1.16	1.16	1.16
29.00	ELEV	603.55	603.54	603.53	603.52	603.51	603.50	603.49	603.49	603.48	603.47

RUNOFF VOLUME ABOVE BASEFLOW = 2.69 WATERSHED INCHES, 103.17 CFS-HRS, 8.53 ACRE-FEET; BASEFLOW = .00 CFS

EXECUTIVE CONTROL OPERATION ENDCMP

COMPUTATIONS COMPLETED FOR PASS 3

RECORD ID

EXECUTIVE CONTROL OPERATION COMPUT

RECORD ID

FROM STRUCTURE 1
TO STRUCTURE 1

STARTING TIME = .00 RAIN DEPTH = 6.70 RAIN DURATION= 1.00 RAIN TABLE NO.= 2 ANT. MOIST. COND= 2
ALTERNATE NO.= 0 STORM NO.=99 MAIN TIME INCREMENT = .10 HOURS

OPERATION RUNOFF STRUCTURE 1

OUTPUT HYDROGRAPH= 4
AREA= .06 SQ MI INPUT RUNOFF CURVE= 90. TIME OF CONCENTRATION= .19 HOURS
INTERNAL HYDROGRAPH TIME INCREMENT= .0253 HOURS

PEAK TIME(HRS)	PEAK DISCHARGE(CFS)	PEAK ELEVATION(FEET)
12.00	243.84	(RUNOFF)
19.65	4.02	(RUNOFF)
23.65	3.02	(RUNOFF)

RUNOFF VOLUME ABOVE BASEFLOW = 5.54 WATERSHED INCHES, 212.45 CFS-HRS, 17.56 ACRE-FEET; BASEFLOW = .00 CFS

OPERATION RESVOR STRUCTURE 1

INPUT HYDROGRAPH= 4 OUTPUT HYDROGRAPH= 5
SURFACE ELEVATION= 599.00

PEAK TIME(HRS)	PEAK DISCHARGE(CFS)	PEAK ELEVATION(FEET)
12.19	117.29	607.00
23.65	3.01	604.06

TIME(HRS)	FIRST HYDROGRAPH POINT = .00 HOURS	TIME INCREMENT = .10 HOURS	DRAINAGE AREA = .06 SQ.MI.								
3.00	DISCHG .00 .00 .00 .00 .00 .01 .01 .01 .02 .02										
3.00	ELEV 599.00 599.00 599.00 599.00 599.00 599.01 599.02 599.02 599.03 599.04										
4.00	DISCHG .03 .03 .04 .05 .06 .06 .07 .08 .09 .09										
4.00	ELEV 599.05 599.06 599.07 599.09 599.10 599.12 599.14 599.16 599.17 599.19										
5.00	DISCHG .10 .10 .11 .11 .12 .12 .13 .13 .14 .15										
5.00	ELEV 599.21 599.23 599.24 599.26 599.29 599.31 599.33 599.35 599.37 599.40										
6.00	DISCHG .15 .16 .17 .18 .19 .20 .21 .22 .23 .24										
6.00	ELEV 599.42 599.45 599.48 599.51 599.55 599.58 599.62 599.65 599.69 599.73										
7.00	DISCHG .25 .26 .27 .28 .29 .30 .31 .31 .32 .32										
7.00	ELEV 599.77 599.81 599.85 599.89 599.93 599.97 600.01 600.05 600.08 600.12										
8.00	DISCHG .32 .32 .32 .32 .33 .33 .33 .34 .34 .34										
8.00	ELEV 600.15 600.19 600.23 600.28 600.32 600.38 600.43 600.49 600.55 600.61										
9.00	DISCHG .35 .35 .35 .36 .36 .36 .37 .37 .38 .38										
9.00	ELEV 600.67 600.73 600.79 600.86 600.93 601.01 601.08 601.16 601.25 601.33										
10.00	DISCHG .39 .40 .53 .63 .67 .71 .75 .78 .81 .84										
10.00	ELEV 601.42 601.51 601.59 601.68 601.77 601.86 601.95 602.04 602.14 602.24										
11.00	DISCHG .87 .91 .95 .99 1.03 1.07 1.13 1.22 12.83 42.28										
11.00	ELEV 602.35 602.47 602.61 602.75 602.90 603.07 603.31 603.77 604.37 605.18										
12.00	DISCHG 90.69 111.95 117.25 110.08 99.65 88.85 72.60 58.60 48.15 40.22										
12.00	ELEV 606.13 606.83 607.00 606.77 606.42 606.07 605.74 605.48 605.29 605.14										
13.00	DISCHG 33.99 30.25 27.49 25.05 22.93 21.04 19.40 17.90 16.57 15.40										
13.00	ELEV 605.03 604.93 604.84 604.76 604.69 604.63 604.58 604.53 604.49 604.45										

14.00	DISCHG	14.37	13.48	12.67	11.95	11.30	10.69	10.14	9.60	9.11	8.69
14.00	ELEV	604.42	604.39	604.37	604.34	604.32	604.30	604.28	604.27	604.25	604.24
15.00	DISCHG	8.35	8.08	7.86	7.68	7.48	7.23	7.00	6.80	6.64	6.51
15.00	ELEV	604.23	604.22	604.21	604.21	604.20	604.19	604.18	604.18	604.17	604.17
16.00	DISCHG	6.41	6.32	6.26	6.21	6.16	6.13	6.07	5.95	5.79	5.64
16.00	ELEV	604.16	604.16	604.16	604.16	604.16	604.16	604.15	604.15	604.14	604.14
17.00	DISCHG	5.51	5.41	5.33	5.26	5.21	5.17	5.14	5.11	5.08	5.00
17.00	ELEV	604.14	604.13	604.13	604.13	604.13	604.13	604.12	604.12	604.12	604.12
18.00	DISCHG	4.86	4.70	4.57	4.45	4.36	4.29	4.24	4.19	4.15	4.12
18.00	ELEV	604.12	604.11	604.11	604.10	604.10	604.10	604.10	604.09	604.09	604.09
19.00	DISCHG	4.10	4.08	4.07	4.05	4.04	4.04	4.03	4.03	4.02	3.95
19.00	ELEV	604.09	604.09	604.09	604.09	604.09	604.09	604.09	604.09	604.09	604.09
20.00	DISCHG	3.82	3.67	3.54	3.44	3.35	3.28	3.23	3.18	3.15	3.12
20.00	ELEV	604.08	604.08	604.07	604.07	604.07	604.06	604.06	604.06	604.06	604.06
21.00	DISCHG	3.10	3.08	3.07	3.05	3.05	3.04	3.03	3.03	3.02	3.02
21.00	ELEV	604.06	604.06	604.06	604.06	604.06	604.06	604.06	604.06	604.06	604.06
22.00	DISCHG	3.02	3.02	3.02	3.01	3.01	3.01	3.01	3.01	3.01	3.01
22.00	ELEV	604.06	604.06	604.06	604.06	604.06	604.06	604.06	604.06	604.06	604.06
23.00	DISCHG	3.01	3.01	3.01	3.01	3.01	3.01	3.01	3.01	3.00	2.94
23.00	ELEV	604.06	604.06	604.06	604.06	604.06	604.06	604.06	604.06	604.06	604.05
24.00	DISCHG	2.81	2.60	2.28	1.88	1.52	1.27	1.27	1.27	1.26	1.26
24.00	ELEV	604.05	604.04	604.03	604.02	604.01	604.00	603.99	603.98	603.97	603.96
25.00	DISCHG	1.26	1.26	1.26	1.25	1.25	1.25	1.25	1.24	1.24	1.24
25.00	ELEV	603.95	603.94	603.93	603.92	603.91	603.90	603.89	603.88	603.87	603.86
26.00	DISCHG	1.24	1.24	1.23	1.23	1.23	1.23	1.23	1.22	1.22	1.22
26.00	ELEV	603.85	603.84	603.83	603.82	603.81	603.80	603.79	603.78	603.77	603.76
27.00	DISCHG	1.22	1.22	1.21	1.21	1.21	1.21	1.21	1.20	1.20	1.20
27.00	ELEV	603.75	603.74	603.73	603.72	603.72	603.71	603.70	603.69	603.68	603.67
28.00	DISCHG	1.20	1.20	1.19	1.19	1.19	1.19	1.19	1.18	1.18	1.18
28.00	ELEV	603.66	603.65	603.64	603.63	603.62	603.61	603.60	603.59	603.58	603.57
29.00	DISCHG	1.18	1.18	1.17	1.17	1.17	1.17	1.17	1.17	1.16	1.16
29.00	ELEV	603.56	603.56	603.55	603.54	603.53	603.52	603.51	603.50	603.49	603.48

RUNOFF VOLUME ABOVE BASEFLOW = 4.53 WATERSHED INCHES, 173.41 CFS-HRS, 14.33 ACRE-FEET; BASEFLOW = .00 CFS

EXECUTIVE CONTROL OPERATION ENDCMP

RECORD ID

COMPUTATIONS COMPLETED FOR PASS 4

EXECUTIVE CONTROL OPERATION ENDJOB

RECORD ID

SUMMARY TABLE 1 - SELECTED RESULTS OF STANDARD AND EXECUTIVE CONTROL INSTRUCTIONS IN THE ORDER PERFORMED
(A STAR(*) AFTER THE PEAK DISCHARGE TIME AND RATE (CFS) VALUES INDICATES A FLAT TOP HYDROGRAPH
A QUESTION MARK(?) INDICATES A HYDROGRAPH WITH PEAK AS LAST POINT.)

SECTION/ STRUCTURE ID	STANDARD CONTROL OPERATION	DRAINAGE AREA (SQ MI)	RAIN TABLE #	ANTEC MOIST COND	MAIN TIME INCREM (HR)	PRECIPITATION			RUNOFF AMOUNT (IN)	PEAK DISCHARGE			
						BEGIN (HR)	AMOUNT (IN)	DURATION (HR)		ELEVATION (FT)	TIME (HR)	RATE (CFS)	RATE (CSM)
ALTERNATE 0 STORM 1													
+													
STRUCTURE 1	RUNOFF	.06	2	2	.10	.0	2.50	24.00	1.54	---	12.01	71.82	1209.6
STRUCTURE 1	RESVOR	.06	2	2	.10	.0	2.50	24.00	.58	603.97	19.80?	1.26?	21.3
ALTERNATE 0 STORM 2													
+													
STRUCTURE 1	RUNOFF	.06	2	2	.10	.0	3.00	24.00	1.99	---	12.01	92.28	1554.2
STRUCTURE 1	RESVOR	.06	2	2	.10	.0	3.00	24.00	1.00	604.19	13.07	7.17	120.8
ALTERNATE 0 STORM 10													
+													
STRUCTURE 1	RUNOFF	.06	2	2	.10	.0	4.80	24.00	3.69	---	12.01	166.34	2801.4
STRUCTURE 1	RESVOR	.06	2	2	.10	.0	4.80	24.00	2.69	605.64	12.22	67.14	1130.8
ALTERNATE 0 STORM 99													
+													
STRUCTURE 1	RUNOFF	.06	2	2	.10	.0	6.70	24.00	5.54	---	12.00	243.84	4106.8
STRUCTURE 1	RESVOR	.06	2	2	.10	.0	6.70	24.00	4.53	607.00	12.19	117.29	1975.4

TR20 XEQ 04-20-06 16:02
REV PC 09/83(.2)

NEW HAVEN
SWM POND '1'

File:TR20\1008A-P1.T20

JOB 1 SUMMARY
PAGE 10

SUMMARY TABLE 3 - DISCHARGE (CFS) AT XSECTIONS AND STRUCTURES FOR ALL STORMS AND ALTERNATES

XSECTION/ STRUCTURE ID	DRAINAGE AREA (SQ MI)	STORM NUMBERS.....			
		1	2	10	99
0 STRUCTURE 1	.06				
+ ALTERNATE 0		1.26	7.17	67.14	117.29

END OF 1 JOBS IN THIS RUN

JOB NUMBER:	1008A
SUBJECT:	NEW HAVEN
	Swm '2'

Site Data:

Site Location: HAGERSTOWN, WASHINGTON COUNTY, MARYLAND

Type of Development: RESIDENTIAL

Rainfall Zone: — [(Western Rainfall Zone) P= 0.9" ←
(Eastern Rainfall Zone) P= 1.0"

Stream Use Designation: Class () Use: (Provide Extended Detention Time: T = Hr)

Proposed Site D.A. = 18[±] ac. ←

Off-Site D.A. = — ac.

Total D.A. to swm pond = 18[±] ac. ←

Total Impervious Area : (From TR-55)

1/8 Ac Lots : 18 ac. @ 65 % = 11.7 ac.

Total Impervious Area = 11.7 AC ←

JOB NUMBER:	1008 A
SUBJECT:	Swm '2'

Water Quality Volume (WQv)

P = 0.9" (Western Rainfall Zone)

A = Drainage Area, (ac.) = 18 AC ±

Total Impervious Area = 11.7 AC.

Rv = Volumetric Runoff Coefficient

I = % Total Impervious Area

$$I = \frac{(\text{Total Impervious Area})}{(A)} \times 100 \% = \frac{(11.7)}{(18)} \times 100 \% = 65 \%$$

$$Rv = 0.05 + 0.009 (I)$$

$$Rv = 0.05 + 0.009 (65) = 0.64$$

$$WQv = \frac{(P)(Rv)(A)}{12} = \frac{(0.9)(0.64)(18)}{12} = 0.86 \text{ ac-ft}$$

$$\text{Check Minimum Required} = \frac{(0.2'')(A)}{12} = \frac{(0.2'')(18)}{12} = 0.30 < 0.86 \text{ ac-ft}$$

Use WQv = 0.86 ac-ft ←

RUNOFF CURVE NUMBER COMPUTATION

Version 2.00

Project : NEW HAVEN

User: JS

Date: 12-30-99

County : WASHINGTON

State: MD

Checked: _____

Date: _____

Subtitle: Existing Conditions: SWM '2'

File: 1008A-E2

COVER DESCRIPTION	Hydrologic Soil Group			
	A	B	C	D
Acres (CN)				
OTHER AGRICULTURAL LANDS				
Meadow -cont. grass (non grazed) -----	-	-	18(71)	-
Total Area (by Hydrologic Soil Group)			18	
			====	

TOTAL DRAINAGE AREA: 18 Acres

WEIGHTED CURVE NUMBER: 71*

* - Generated for use by GRAPHIC method

TIME OF CONCENTRATION AND TRAVEL TIME

Version 2.00

Project : NEW HAVEN

User: JS

Date: 12-30-99

County : WASHINGTON

State: MD

Checked: _____

Date: _____

Subtitle: Existing Conditions: SWM '2'

File: 1008A-E2

Flow Type	2 year rain	Length (ft)	Slope (ft/ft)	Surface code	n	Area (sq/ft)	Wp (ft)	Velocity (ft/sec)	Time (hr)
Sheet	3.0	50	0.02	F					0.141
Shallow Concent'd		1000	0.06	U					0.070

Time of Concentration = 0.21*

=====

--- Sheet Flow Surface Codes ---

- A Smooth Surface
- B Fallow (No Res.)
- C Cultivated < 20 % Res.
- D Cultivated > 20 % Res.
- E Grass-Range, Short
- F Grass, Dense
- G Grass, Burmuda
- H Woods, Light
- I Woods, Dense
- J Range, Natural

- Shallow Concentrated ---
- Surface Codes ---
- P Paved
- U Unpaved

* - Generated for use by GRAPHIC method

GRAPHICAL PEAK DISCHARGE METHOD

Version 2.00

Project : NEW HAVEN

User: JS

Date: 12-30-99

County : WASHINGTON

State: MD

Checked: _____

Date: _____

Subtitle: Existing Conditions: SWM '2'

File: 1008A-E2

Data: Drainage Area : 18 * Acres
 Runoff Curve Number : 71 *
 Time of Concentration: 0.21 * Hours
 Rainfall Type : II
 Pond and Swamp Area : NONE

Storm Number	1	2	3	4	5	6	7
Frequency (yrs)	1	2	5	10	25	50	100
24-Hr Rainfall (in)	2.5	3	3.9	4.8	5.1	6	6.7
Ia/P Ratio	0.33	0.27	0.21	0.17	0.16	0.14	0.12
Runoff (in)	0.49	0.76	1.33	1.97	2.19	2.90	3.47
Unit Peak Discharge (cfs/acre/in)	1.018	1.088	1.138	1.170	1.178	1.197	1.209
Pond and Swamp Factor 0.0% Ponds Used	1.00	1.00	1.00	1.00	1.00	1.00	1.00
Peak Discharge (cfs)	9	15	27	41	46	62	76

* - Value(s) provided from TR-55 system routines

*****80-80 LIST OF INPUT DATA FOR TR-20 HYDROLOGY*****

JOB TR-20
 TITLE 001 NEW HAVEN
 TITLE Existing Conditions SWM Pond '2'
 6 RUNOFF 1 001 1 0.02812500 71 0.21
 ENDDATA
 7 INCREM 6 0.10
 7 COMPUT 7 001 001 2.5 1.0 2 2 01 1
 ENDCMP 1
 7 COMPUT 7 001 001 3.0 1.0 2 2 01 2
 ENDCMP 1
 7 COMPUT 7 001 001 4.8 1.0 2 2 01 10
 ENDCMP 1
 7 COMPUT 7 001 001 6.7 1.0 2 2 01 99
 ENDCMP 1
 ENDJOB 2

SUMMARY
 File: TR20\1008A-E2.T20

EXISTING
 (PRE-DEVELOPED)
 CONDITIONS

0*****END OF 80-80 LIST*****

EXECUTIVE CONTROL OPERATION INCREM RECORD ID
 + MAIN TIME INCREMENT = .10 HOURS

EXECUTIVE CONTROL OPERATION COMPUT RECORD ID
 + FROM XSECTION 1
 + TO XSECTION 1
 STARTING TIME = .00 RAIN DEPTH = 2.50 RAIN DURATION= 1.00 RAIN TABLE NO.= 2 ANT. MOIST. COND= 2
 ALTERNATE NO.= 1 STORM NO.= 1 MAIN TIME INCREMENT = .10 HOURS

EXECUTIVE CONTROL OPERATION ENDCMP RECORD ID
 + COMPUTATIONS COMPLETED FOR PASS 1

EXECUTIVE CONTROL OPERATION COMPUT RECORD ID
 + FROM XSECTION 1
 + TO XSECTION 1
 STARTING TIME = .00 RAIN DEPTH = 3.00 RAIN DURATION= 1.00 RAIN TABLE NO.= 2 ANT. MOIST. COND= 2
 ALTERNATE NO.= 1 STORM NO.= 2 MAIN TIME INCREMENT = .10 HOURS

EXECUTIVE CONTROL OPERATION ENDCMP RECORD ID
 + COMPUTATIONS COMPLETED FOR PASS 2

EXECUTIVE CONTROL OPERATION COMPUT RECORD ID
 + FROM XSECTION 1
 + TO XSECTION 1
 STARTING TIME = .00 RAIN DEPTH = 4.80 RAIN DURATION= 1.00 RAIN TABLE NO.= 2 ANT. MOIST. COND= 2
 ALTERNATE NO.= 1 STORM NO.=10 MAIN TIME INCREMENT = .10 HOURS

EXECUTIVE CONTROL OPERATION ENDCMP RECORD ID
 + COMPUTATIONS COMPLETED FOR PASS 3

EXECUTIVE CONTROL OPERATION COMPUT RECORD ID
 + FROM XSECTION 1
 + TO XSECTION 1
 STARTING TIME = .00 RAIN DEPTH = 6.70 RAIN DURATION= 1.00 RAIN TABLE NO.= 2 ANT. MOIST. COND= 2

ALTERNATE NO.= 1 STORM NO.=99 MAIN TIME INCREMENT = .10 HOURS

EXECUTIVE CONTROL OPERATION ENDCMP

RECORD ID

+ COMPUTATIONS COMPLETED FOR PASS 4

EXECUTIVE CONTROL OPERATION ENDAJOB

RECORD ID

SUMMARY TABLE 1 - SELECTED RESULTS OF STANDARD AND EXECUTIVE CONTROL INSTRUCTIONS IN THE ORDER PERFORMED
 (A STAR(*) AFTER THE PEAK DISCHARGE TIME AND RATE (CFS) VALUES INDICATES A FLAT TOP HYDROGRAPH
 A QUESTION MARK(?) INDICATES A HYDROGRAPH WITH PEAK AS LAST POINT.)

SECTION/ STRUCTURE ID	STANDARD CONTROL OPERATION	DRAINAGE AREA (SQ MI)	RAIN TABLE #	ANTEC MOIST COND	MAIN TIME INCREM (HR)	PRECIPITATION			RUNOFF AMOUNT (IN)	PEAK DISCHARGE				
						BEGIN (HR)	AMOUNT (IN)	DURATION (HR)		ELEVATION (FT)	TIME (HR)	RATE (CFS)	RATE (CSM)	
ALTERNATE 1 STORM 1														
+ XSECTION	1	RUNOFF	.03	2	2	.10	.0	2.50	24.00	.49	---	12.07	9.42	334.8
ALTERNATE 1 STORM 2														
+ XSECTION	1	RUNOFF	.03	2	2	.10	.0	3.00	24.00	.76	---	12.06	15.51	551.3
ALTERNATE 1 STORM 10														
+ XSECTION	1	RUNOFF	.03	2	2	.10	.0	4.80	24.00	1.97	---	12.04	42.37	1506.7
ALTERNATE 1 STORM 99														
+ XSECTION	1	RUNOFF	.03	2	2	.10	.0	6.70	24.00	3.48	---	12.03	75.33	2678.4

SUMMARY TABLE 3 - DISCHARGE (CFS) AT XSECTIONS AND STRUCTURES FOR ALL STORMS AND ALTERNATES

XSECTION/ STRUCTURE ID	DRAINAGE AREA (SQ MI)	STORM NUMBERS.....			
		1	2	10	99
0 XSECTION	1				
+					
ALTERNATE	1	9.42	15.51	42.37	75.33
		↑	↑	↑	↑
		Q_1	Q_2	Q_{10}	Q_{100}

← Q_{PRE}
 SWM '2'

END OF 1 JOBS IN THIS RUN

RUNOFF CURVE NUMBER COMPUTATION

Version 2.00

Project : NEW HAVEN

User: JS

Date: 12-30-99

County : WASHINGTON

State: MD

Checked: _____

Date: _____

Subtitle: Proposed Conditions: SWM '2'

File: 1008A-P2

COVER DESCRIPTION	Hydrologic Soil Group			
	A	B	C	D
	Acres (CN)			
FULLY DEVELOPED URBAN AREAS (Veg Estab.)				
Residential districts				
(by average lot size)				
1/8 acre (town houses)	65	-	-	18(90)
Total Area (by Hydrologic Soil Group)			18	====

TOTAL DRAINAGE AREA: 18 Acres

WEIGHTED CURVE NUMBER: 90*

* - Generated for use by GRAPHIC method

TIME OF CONCENTRATION AND TRAVEL TIME

Version 2.00

Project : NEW HAVEN

User: JS

Date: 12-30-99

County : WASHINGTON

State: MD

Checked: _____

Date: _____

Subtitle: Proposed Conditions: SWM '2'

File: 1008A-P2

Flow Type	2 year rain	Length (ft)	Slope (ft/ft)	Surface code	n	Area (sq/ft)	Wp (ft)	Velocity (ft/sec)	Time (hr)
Sheet	3.0	50	0.02	E					0.097
Shallow Concent'd		200	0.02	P					0.019
Open Channel		800					8		0.028

Time of Concentration = 0.14*

=====

--- Sheet Flow Surface Codes ---

A Smooth Surface

F Grass, Dense

--- Shallow Concentrated ---

B Fallow (No Res.)

G Grass, Burmuda

--- Surface Codes ---

C Cultivated < 20 % Res.

H Woods, Light

P Paved

D Cultivated > 20 % Res.

I Woods, Dense

U Unpaved

E Grass-Range, Short

J Range, Natural

* - Generated for use by GRAPHIC method

GRAPHICAL PEAK DISCHARGE METHOD

Version 2.00

Project : NEW HAVEN

User: JS

Date: 12-30-99

County : WASHINGTON

State: MD

Checked: _____

Date: _____

Subtitle: Proposed Conditions: SWM '2'

File: 1008A-P2

Data: Drainage Area : 18 * Acres
 Runoff Curve Number : 90 *
 Time of Concentration: 0.14 * Hours
 Rainfall Type : II
 Pond and Swamp Area : NONE

Storm Number	1	2	3	4	5	6	7
Frequency (yrs)	1	2	5	10	25	50	100
24-Hr Rainfall (in)	2.5	3	3.9	4.8	5.1	6	6.7
Ia/P Ratio	0.09	0.07	0.06	0.05	0.04	0.04	0.03
Used	0.10	0.10	0.10	0.10	0.10	0.10	0.10
Runoff (in)	1.53	1.98	2.82	3.68	3.97	4.85	5.53
Unit Peak Discharge (cfs/acre/in)	1.421	1.421	1.421	1.421	1.421	1.421	1.421
Pond and Swamp Factor 0.0% Ponds Used	1.00	1.00	1.00	1.00	1.00	1.00	1.00
Peak Discharge (cfs)	39	51	72	94	102	124	141

* - Value(s) provided from TR-55 system routines

JOB NUMBER: 1008A
SUBJECT: SWM '2'

Pond Pretreatment \ Sedimentation Forebay

Size Forebay to Treat 0.10" per total Impervious Area.

Total Impervious Area = 11.7 ac.

$$V_{\text{Req'd.}} = (11.7 \text{ ac.}) (0.10") (1' / 12") = 0.10 \text{ ac-ft}$$

$$V_{\text{Provided}} = \underline{\underline{0.126}} \text{ ac-ft} \quad \leftarrow$$

" Forebay Storage Volume "

Elev.	Area (ft ²)	Average Area (ft ²)	Depth (ft)	Volume (ft ³)	Σ Volume (ft ³)	Σ Volume (ac-ft)
589.5	2200				0	0
		2200	2.5'	5500		
592	2200				5500	0.126

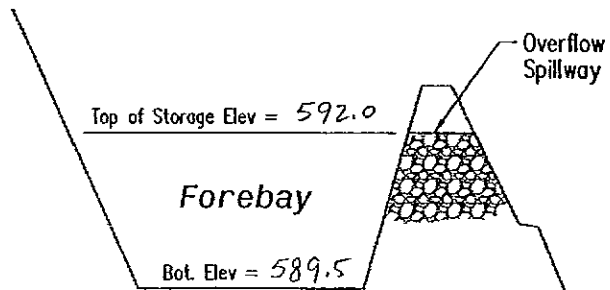

RODGERS CONSULTING, INC.
 19847 Century Blvd. (Suite 200)
 Germantown, MD 20874
 301-948-4700

USER:
 DATE: 4/21/2006
 CHECKED BY:
 JOB NO.:
 FILE NAME:

SWM POND '2'
 STAGE/STORAGE TABULATION
 PLAN SCALE 1in. = 1

ELEV.	AREA SQ. IN.	AREA SQ. FT.	AVG. AREA SQ. FT.	ELEV. DIFF. FT.	INCR. VOLUME CU. FT.	TOTAL VOLUME CU. FT.	TOTAL VOLUME AC. FT.
582	1500	1500				0	0
			2250	2.0	4500		
584	3000	3000				4500	0.1033
			3750	2.0	7500		
586	4500	4500				12000	0.2755
			5100	1.0	5100		
587	5700	5700				17100	0.3926
			7050	0.10	705		
587.1	8400	8400				17805	0.4087
			9700	0.90	8730		
<u>588</u>	<u>11000</u>	<u>11000</u>				<u>26535</u>	<u>0.6092</u>
			11100	0.12	1332		
588.12	11200	11200				27867	0.6397 0.0305
			12350	0.88	10868		
589	13500	13500				38735	0.8892 0.2800
			14750	1.00	14750		
590 *	16000	16000				53485	1.2278 0.6186
			16100	0.12	1932		
590.12 *	16200	16200				55417	1.2722 0.6630
			16725	0.88	14718		
591 *	17250	17250				70135	1.6101 1.0009
			17875	0.80	14300		
591.8 *	18500	18500				84435	1.9384 1.3292
			20750	0.20	4150		
592 *	23000	23000				88585	2.0336 1.4244
			23625	1.00	23625		
593 *	24250	24250				112210	2.5760 1.9668
			24875	1.00	24875		
594 *	25500	25500				137085	3.1470 2.5378
			26250	1.00	26250		
595 *	27000	27000				163335	3.7497 3.1405
			27750	1.00	27750		
596 *	28500	28500				191085	4.3867 3.7775
			#N/A	#N/A	#N/A		
0	0	0				#N/A	#N/A
			0	0.0	0		
0	0	0				#N/A	#N/A
			0	0.0	0		
0	0	0				#N/A	#N/A
			0	0.0	0		
0	0	0				#N/A	#N/A

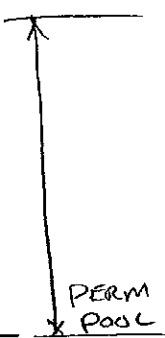

* INCLUDES FOREBAY STORAGE

0.00	582
0.10	584
0.28	586
0.39	587
0.41	587.1
0.61	588
0.64	588.12
0.89	589
1.23	590
1.27	590.12
1.61	591
1.94	591.8
2.03	592
2.58	593
3.15	594
3.75	595
4.39	596
#N/A	0
#N/A	0
#N/A	0
#N/A	0

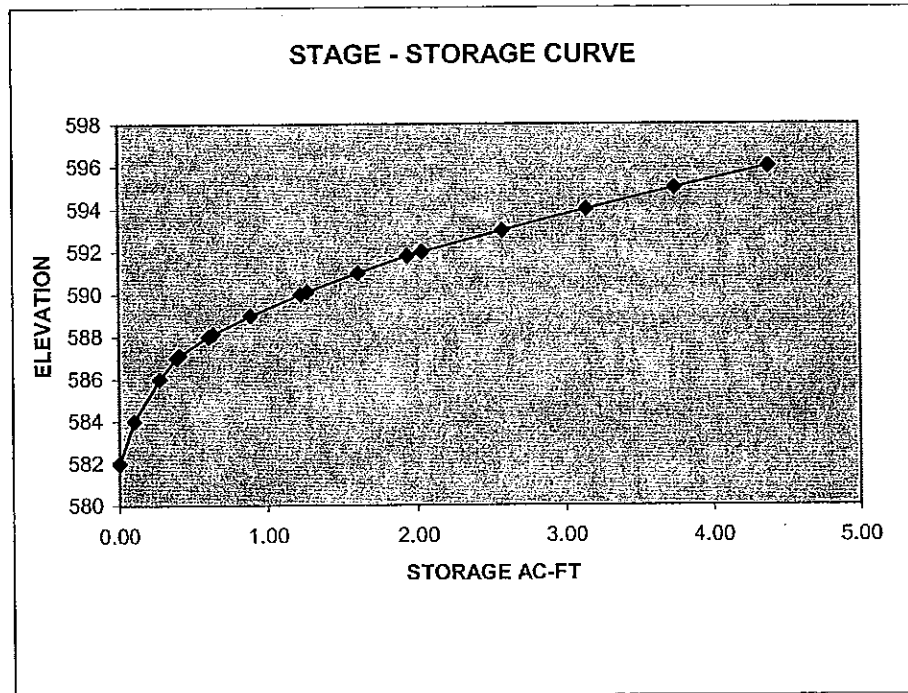

Sum '2'

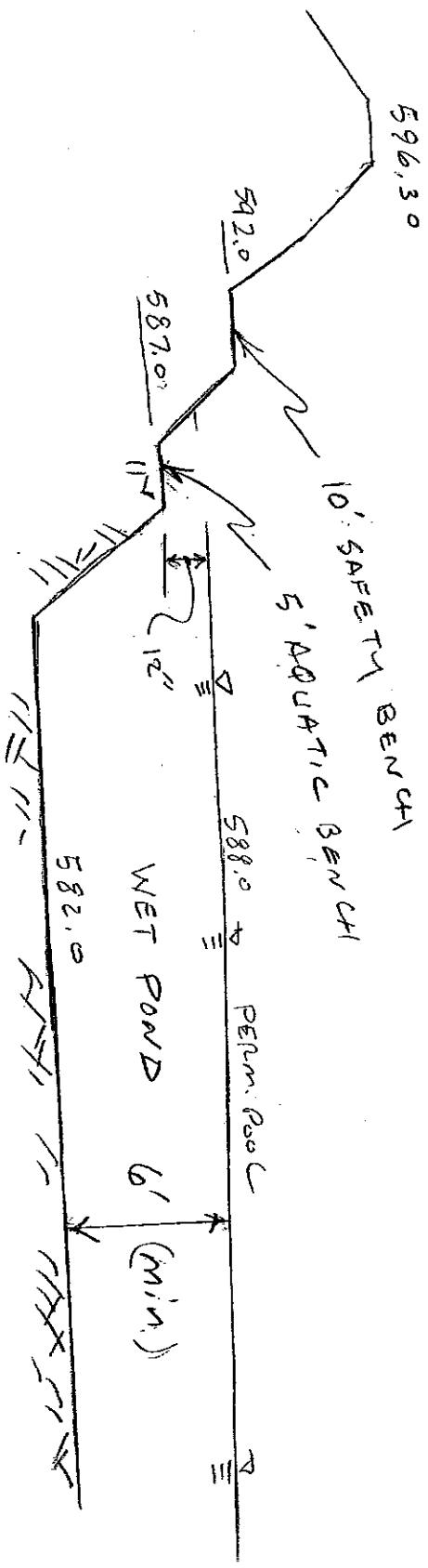
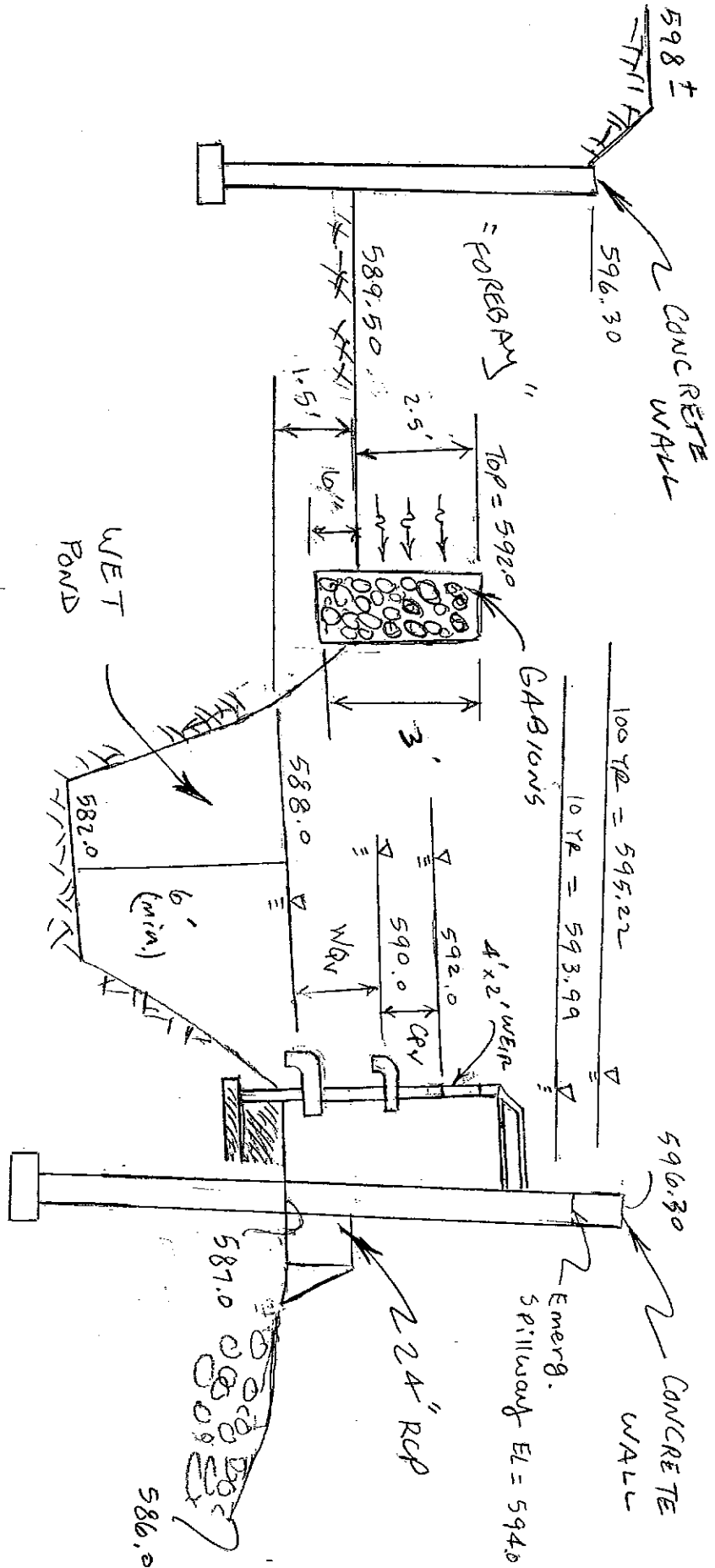

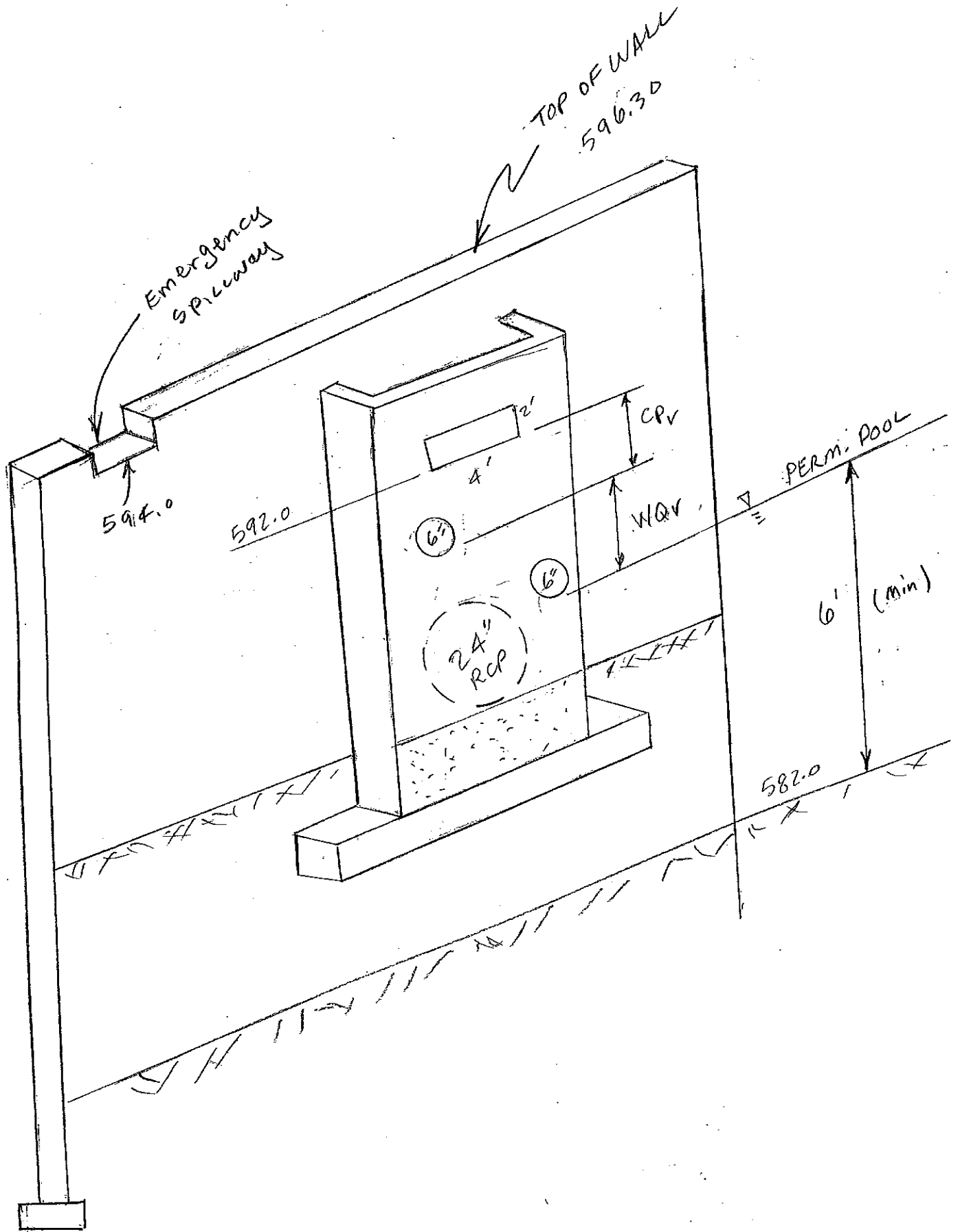

*****80-80 LIST OF INPUT DATA FOR TR-20 HYDROLOGY*****

```

JOB TR-20                FULLPRINT
TITLE 001  NEW HAVEN                File:TR20\1008A-P2.T20
TITLE 002  SWM POND '2'
3 STRUCT      01
8              588.00      0.00      0.000
8              588.12      0.05      0.0305
8              589.00      0.22      0.2800
8              590.00      0.32      0.6186
8              590.12      0.38      0.6630
8              591.00      0.62      1.0009
8              591.80      0.76      1.3292
8              592.00      0.78      1.4244
8              593.00      13.32     1.9668
8              594.00      36.10     2.5378
8              595.00      64.87     3.1405
8              596.00      112.94    3.7775
9 ENDITBL
6 RUNOFF 1    01    4    0.02812500    90    0.14 1    1
6 RESVOR 2    01  4    5    588.0      0      1 1 1 1    1
  ENDDATA
7 INCREM 6              0.1
7 COMPUT 7    01    01    0.0      2.5      1.02 2    01
  ENDCMP 1
7 COMPUT 7    01    01    0.0      3.0      1.02 2    02
  ENDCMP 1
7 COMPUT 7    01    01    0.0      4.8      1.02 2    10
  ENDCMP 1
7 COMPUT 7    01    01    0.0      6.7      1.02 2    99
  ENDCMP 1
  ENDJOB 2

```

0*****END OF 80-80 LIST*****

EXECUTIVE CONTROL OPERATION INCREM

RECORD ID

MAIN TIME INCREMENT = .10 HOURS

EXECUTIVE CONTROL OPERATION COMPUT

RECORD ID

FROM STRUCTURE 1

TO STRUCTURE 1

STARTING TIME = .00 RAIN DEPTH = 2.50 RAIN DURATION= 1.00 RAIN TABLE NO.= 2 ANT. MOIST. COND= 2
 ALTERNATE NO.= 0 STORM NO.= 1 MAIN TIME INCREMENT = .10 HOURS

OPERATION RUNOFF STRUCTURE 1

OUTPUT HYDROGRAPH= 4

AREA= .03 SQ MI INPUT RUNOFF CURVE= 90. TIME OF CONCENTRATION= .14 HOURS

INTERNAL HYDROGRAPH TIME INCREMENT= .0187 HOURS

PEAK TIME (HRS) PEAK DISCHARGE (CFS) PEAK ELEVATION (FEET)
 11.98 37.12 (RUNOFF)

RUNOFF VOLUME ABOVE BASEFLOW = 1.53 WATERSHED INCHES, 27.76 CFS-HRS, 2.29 ACRE-FEET; BASEFLOW = .00 CFS

OPERATION RESVOR STRUCTURE 1

INPUT HYDROGRAPH= 4 OUTPUT HYDROGRAPH= 5

SURFACE ELEVATION= 588.00

PEAK TIME (HRS) PEAK DISCHARGE (CFS) PEAK ELEVATION (FEET)
 13.60 1.87 592.09

TIME (HRS)	FIRST HYDROGRAPH POINT = .00 HOURS	TIME INCREMENT = .10 HOURS	DRAINAGE AREA = .03 SQ.MI.								
7.00	DISCHG .00	.00	.00	.00	.00	.00	.00	.01	.01	.01	.01
7.00	ELEV 588.00	588.00	588.00	588.00	588.00	588.00	588.01	588.01	588.02	588.02	588.02
8.00	DISCHG .01	.01	.01	.02	.02	.02	.02	.02	.03	.03	.03
8.00	ELEV 588.02	588.03	588.03	588.04	588.04	588.05	588.05	588.06	588.07	588.07	588.07
9.00	DISCHG .03	.04	.04	.04	.05	.05	.05	.06	.06	.06	.06
9.00	ELEV 588.08	588.09	588.10	588.11	588.12	588.13	588.14	588.15	588.16	588.17	588.17
10.00	DISCHG .06	.06	.07	.07	.07	.08	.08	.09	.09	.10	.10
10.00	ELEV 588.18	588.20	588.21	588.23	588.24	588.26	588.29	588.31	588.34	588.37	588.37
11.00	DISCHG .11	.11	.12	.13	.14	.15	.18	.22	.25	.30	.30
11.00	ELEV 588.41	588.45	588.49	588.54	588.59	588.65	588.77	589.00	589.29	589.83	589.83
12.00	DISCHG .50	.65	.71	.73	.75	.76	.77	.77	.78	.86	.86
12.00	ELEV 590.56	591.18	591.49	591.64	591.74	591.81	591.87	591.92	591.97	592.01	592.01
13.00	DISCHG 1.20	1.46	1.63	1.75	1.82	1.86	1.87	1.86	1.83	1.80	1.80
13.00	ELEV 592.03	592.05	592.07	592.08	592.08	592.09	592.09	592.09	592.08	592.08	592.08
14.00	DISCHG 1.76	1.72	1.67	1.62	1.57	1.52	1.47	1.41	1.36	1.31	1.31
14.00	ELEV 592.08	592.07	592.07	592.07	592.06	592.06	592.05	592.05	592.05	592.04	592.04
15.00	DISCHG 1.27	1.24	1.22	1.20	1.17	1.13	1.10	1.07	1.05	1.03	1.03
15.00	ELEV 592.04	592.04	592.03	592.03	592.03	592.03	592.03	592.02	592.02	592.02	592.02
16.00	DISCHG 1.02	1.00	.99	.99	.98	.97	.96	.94	.92	.90	.90
16.00	ELEV 592.02	592.02	592.02	592.02	592.02	592.02	592.01	592.01	592.01	592.01	592.01
17.00	DISCHG .88	.86	.85	.84	.83	.83	.82	.82	.81	.80	.80
17.00	ELEV 592.01	592.01	592.01	592.00	592.00	592.00	592.00	592.00	592.00	592.00	592.00

TR20 XEQ 04-25-06 08:37
 REV PC 09/83(.2)

NEW HAVEN
 SWM POND '2'

File:TR20\1008A-P2.T20

JOB 1 PASS 1
 PAGE 2

18.00	DISCHG	.78	.78	.78	.78	.78	.78	.78	.78	.78	.78
18.00	ELEV	592.00	592.00	591.99	591.99	591.99	591.99	591.98	591.98	591.98	591.98
19.00	DISCHG	.78	.78	.78	.78	.78	.78	.78	.78	.78	.78
19.00	ELEV	591.97	591.97	591.97	591.97	591.97	591.96	591.96	591.96	591.96	591.95
20.00	DISCHG	.77	.77	.77	.77	.77	.77	.77	.77	.77	.77
20.00	ELEV	591.95	591.94	591.94	591.93	591.93	591.92	591.92	591.91	591.91	591.90
21.00	DISCHG	.77	.77	.77	.77	.77	.77	.77	.77	.77	.77
21.00	ELEV	591.90	591.89	591.89	591.88	591.88	591.87	591.87	591.86	591.86	591.85
22.00	DISCHG	.76	.76	.76	.76	.76	.76	.76	.76	.76	.76
22.00	ELEV	591.85	591.84	591.84	591.83	591.83	591.82	591.82	591.81	591.81	591.80
23.00	DISCHG	.76	.76	.76	.76	.76	.76	.75	.75	.75	.75
23.00	ELEV	591.80	591.79	591.79	591.78	591.78	591.77	591.77	591.76	591.76	591.75
24.00	DISCHG	.75	.75	.75	.74	.74	.74	.74	.73	.73	.73
24.00	ELEV	591.74	591.73	591.72	591.70	591.69	591.67	591.66	591.64	591.63	591.61
25.00	DISCHG	.72	.72	.72	.72	.71	.71	.71	.71	.70	.70
25.00	ELEV	591.60	591.58	591.57	591.56	591.54	591.53	591.51	591.50	591.48	591.47
26.00	DISCHG	.70	.70	.69	.69	.69	.69	.69	.68	.68	.68
26.00	ELEV	591.46	591.44	591.43	591.41	591.40	591.39	591.37	591.36	591.34	591.33
27.00	DISCHG	.68	.67	.67	.67	.67	.66	.66	.66	.66	.65
27.00	ELEV	591.32	591.30	591.29	591.28	591.26	591.25	591.24	591.22	591.21	591.20
28.00	DISCHG	.65	.65	.65	.65	.64	.64	.64	.64	.63	.63
28.00	ELEV	591.18	591.17	591.16	591.14	591.13	591.12	591.11	591.09	591.08	591.07
29.00	DISCHG	.63	.63	.63	.62	.62	.62	.61	.61	.61	.60
29.00	ELEV	591.05	591.04	591.03	591.02	591.00	590.99	590.98	590.96	590.95	590.94

RUNOFF VOLUME ABOVE BASEFLOW = .88 WATERSHED INCHES, 15.89 CFS-HRS, 1.31 ACRE-FEET; BASEFLOW = .00 CFS

EXECUTIVE CONTROL OPERATION ENDCMP

RECORD ID

COMPUTATIONS COMPLETED FOR PASS. 1

EXECUTIVE CONTROL OPERATION COMPUT

RECORD ID

+ FROM STRUCTURE 1 TO STRUCTURE 1
+ STARTING TIME = .00 RAIN DEPTH = 3.00 RAIN DURATION= 1.00 RAIN TABLE NO.= 2 ANT. MOIST. COND= 2
ALTERNATE NO.= 0 STORM NO.= 2 MAIN TIME INCREMENT = .10 HOURS

OPERATION RUNOFF STRUCTURE 1

OUTPUT HYDROGRAPH= 4
AREA= .03 SQ MI INPUT RUNOFF CURVE= 90. TIME OF CONCENTRATION= .14 HOURS
INTERNAL HYDROGRAPH TIME INCREMENT= .0187 HOURS

PEAK TIME(HRS) PEAK DISCHARGE(CFS) PEAK ELEVATION(FEET)
11.98 47.59 (RUNOFF)

RUNOFF VOLUME ABOVE BASEFLOW = 1.98 WATERSHED INCHES, 35.98 CFS-HRS, 2.97 ACRE-FEET; BASEFLOW = .00 CFS

OPERATION RESVOR STRUCTURE 1

INPUT HYDROGRAPH= 4 OUTPUT HYDROGRAPH= 5
SURFACE ELEVATION= 588.00

PEAK TIME(HRS) PEAK DISCHARGE(CFS) PEAK ELEVATION(FEET)
12.44 5.83 592.40

TIME(HRS)	FIRST HYDROGRAPH POINT =	.00 HOURS	TIME INCREMENT =	.10 HOURS	DRAINAGE AREA =	.03 SQ.MI.
6.00	DISCHG	.00	.00	.00	.01	.01
6.00	ELEV	588.00	588.00	588.00	588.01	588.02
7.00	DISCHG	.01	.01	.02	.02	.03
7.00	ELEV	588.02	588.03	588.04	588.05	588.06
8.00	DISCHG	.03	.04	.04	.05	.06
8.00	ELEV	588.07	588.08	588.10	588.11	588.12
9.00	DISCHG	.06	.06	.07	.07	.08
9.00	ELEV	588.17	588.18	588.19	588.21	588.22
10.00	DISCHG	.09	.10	.11	.11	.12
10.00	ELEV	588.33	588.35	588.37	588.42	588.45
11.00	DISCHG	.15	.16	.18	.20	.22
11.00	ELEV	588.65	588.71	588.77	588.84	589.00
12.00	DISCHG	.68	1.18	4.52	5.80	5.78
12.00	ELEV	591.33	592.03	592.30	592.40	592.39
13.00	DISCHG	4.79	4.54	4.28	4.03	3.80
13.00	ELEV	592.32	592.30	592.28	592.26	592.24
14.00	DISCHG	2.68	2.54	2.41	2.30	2.19
14.00	ELEV	592.15	592.14	592.13	592.12	592.11
15.00	DISCHG	1.66	1.61	1.56	1.53	1.48
15.00	ELEV	592.07	592.07	592.06	592.06	592.06
16.00	DISCHG	1.27	1.26	1.24	1.23	1.22
16.00	ELEV	592.04	592.04	592.04	592.04	592.04
17.00	DISCHG	1.09	1.07	1.06	1.04	1.03
17.00	ELEV	592.02	592.02	592.02	592.02	592.02
18.00	DISCHG	.96	.93	.90	.88	.87

TR20 XEQ 04-25-06 08:37
REV PC 09/83 (.2)

NEW HAVEN
SWM POND '2'

File:TR20\1008A-P2.T20

JOB 1 PASS 2
PAGE 4

18.00	ELEV	592.01	592.01	592.01	592.01	592.01	592.01	592.01	592.00	592.00	592.00
19.00	DISCHG	.82	.81	.81	.81	.80	.80	.80	.80	.80	.78
19.00	ELEV	592.00	592.00	592.00	592.00	592.00	592.00	592.00	592.00	592.00	592.00
20.00	DISCHG	.78	.78	.78	.78	.78	.78	.78	.78	.78	.78
20.00	ELEV	592.00	591.99	591.99	591.99	591.98	591.98	591.98	591.97	591.97	591.97
21.00	DISCHG	.78	.78	.78	.78	.78	.78	.77	.77	.77	.77
21.00	ELEV	591.97	591.96	591.96	591.96	591.95	591.95	591.95	591.94	591.94	591.94
22.00	DISCHG	.77	.77	.77	.77	.77	.77	.77	.77	.77	.77
22.00	ELEV	591.93	591.93	591.93	591.93	591.92	591.92	591.92	591.91	591.91	591.91
23.00	DISCHG	.77	.77	.77	.77	.77	.77	.77	.77	.77	.77
23.00	ELEV	591.90	591.90	591.90	591.90	591.89	591.89	591.89	591.88	591.88	591.88
24.00	DISCHG	.77	.77	.77	.76	.76	.76	.76	.76	.75	.75
24.00	ELEV	591.87	591.86	591.85	591.84	591.82	591.81	591.80	591.78	591.77	591.75
25.00	DISCHG	.75	.75	.74	.74	.74	.74	.73	.73	.73	.73
25.00	ELEV	591.74	591.72	591.71	591.69	591.68	591.66	591.65	591.63	591.62	591.60
26.00	DISCHG	.72	.72	.72	.72	.71	.71	.71	.71	.70	.70
26.00	ELEV	591.59	591.57	591.56	591.55	591.53	591.52	591.50	591.49	591.47	591.46
27.00	DISCHG	.70	.70	.69	.69	.69	.69	.68	.68	.68	.68
27.00	ELEV	591.45	591.43	591.42	591.40	591.39	591.38	591.36	591.35	591.34	591.32
28.00	DISCHG	.67	.67	.67	.67	.66	.66	.66	.66	.66	.65
28.00	ELEV	591.31	591.29	591.28	591.27	591.25	591.24	591.23	591.21	591.20	591.19
29.00	DISCHG	.65	.65	.65	.64	.64	.64	.64	.63	.63	.63
29.00	ELEV	591.17	591.16	591.15	591.14	591.12	591.11	591.10	591.08	591.07	591.06

RUNOFF VOLUME ABOVE BASEFLOW = 1.29 WATERSHED INCHES, 23.49 CFS-HRS, 1.94 ACRE-FEET; BASEFLOW = .00 CFS

EXECUTIVE CONTROL OPERATION ENDCMP

COMPUTATIONS COMPLETED FOR PASS 2

RECORD ID

EXECUTIVE CONTROL OPERATION COMPUT

RECORD ID

FROM STRUCTURE 1

TO STRUCTURE 1

STARTING TIME = .00 RAIN DEPTH = 4.80 RAIN DURATION= 1.00 RAIN TABLE NO.= 2 ANT. MOIST. COND= 2
ALTERNATE NO.= 0 STORM NO.=10 MAIN TIME INCREMENT = .10 HOURS

OPERATION RUNOFF STRUCTURE 1

OUTPUT HYDROGRAPH= 4

AREA= .03 SQ MI INPUT RUNOFF CURVE= 90. TIME OF CONCENTRATION= .14 HOURS

INTERNAL HYDROGRAPH TIME INCREMENT= .0187 HOURS

PEAK TIME(HRS)	PEAK DISCHARGE(CFS)	PEAK ELEVATION(FEET)
11.98	85.43	(RUNOFF)
23.65	1.01	(RUNOFF)

RUNOFF VOLUME ABOVE BASEFLOW = 3.68 WATERSHED INCHES, 66.81 CFS-HRS, 5.52 ACRE-FEET; BASEFLOW = .00 CFS

OPERATION RESVOR STRUCTURE 1

INPUT HYDROGRAPH= 4 OUTPUT HYDROGRAPH= 5

SURFACE ELEVATION= 588.00

PEAK TIME(HRS)	PEAK DISCHARGE(CFS)	PEAK ELEVATION(FEET)
12.15	35.89	593.99

TIME(HRS)	FIRST HYDROGRAPH POINT = .00 HOURS	TIME INCREMENT = .10 HOURS	DRAINAGE AREA = .03 SQ.MI.
4.00	DISCHG .00 .00 .00 .00 .00 .00 .00 .00 .01 .01 .01		
4.00	ELEV 588.00 588.00 588.00 588.00 588.00 588.00 588.00 588.00 588.01 588.02 588.02		
5.00	DISCHG .01 .01 .02 .02 .02 .02 .03 .03 .03 .03 .04		
5.00	ELEV 588.03 588.03 588.04 588.05 588.05 588.05 588.06 588.07 588.07 588.08 588.09		
6.00	DISCHG .04 .05 .05 .05 .05 .06 .06 .06 .06 .06 .07		
6.00	ELEV 588.10 588.11 588.12 588.13 588.14 588.16 588.17 588.18 588.18 588.20 588.21		
7.00	DISCHG .07 .07 .08 .08 .08 .09 .09 .09 .09 .10 .10		
7.00	ELEV 588.22 588.24 588.26 588.27 588.29 588.30 588.32 588.34 588.34 588.35 588.37		
8.00	DISCHG .10 .11 .11 .11 .12 .12 .13 .13 .14 .14 .15		
8.00	ELEV 588.39 588.41 588.43 588.45 588.48 588.51 588.54 588.57 588.57 588.60 588.63		
9.00	DISCHG .15 .16 .17 .17 .18 .18 .19 .19 .20 .21 .22		
9.00	ELEV 588.66 588.69 588.73 588.77 588.80 588.84 588.88 588.93 588.93 588.97 589.02		
10.00	DISCHG .23 .23 .23 .24 .24 .25 .26 .26 .26 .27 .28		
10.00	ELEV 589.06 589.10 589.14 589.19 589.24 589.30 589.36 589.43 589.43 589.51 589.60		
11.00	DISCHG .29 .30 .31 .33 .33 .39 .42 .49 .62 .73 6.43		
11.00	ELEV 589.69 589.79 589.91 590.02 590.15 590.28 590.53 590.99 591.61 592.45		
12.00	DISCHG 22.43 35.17 35.31 30.32 25.26 20.89 17.47 14.79 12.95 11.88		
12.00	ELEV 593.40 593.96 593.97 593.75 593.52 593.33 593.18 593.06 592.97 592.88		
13.00	DISCHG 10.87 9.96 9.14 8.40 7.75 7.15 6.63 6.14 5.70 5.31		
13.00	ELEV 592.80 592.73 592.67 592.61 592.56 592.51 592.47 592.43 592.39 592.36		
14.00	DISCHG 4.97 4.66 4.39 4.14 3.91 3.69 3.50 3.31 3.14 3.00		
14.00	ELEV 592.33 592.31 592.29 592.27 592.25 592.23 592.22 592.20 592.19 592.18		
15.00	DISCHG 2.88 2.78 2.70 2.63 2.55 2.46 2.38 2.31 2.25 2.21		
15.00	ELEV 592.17 592.16 592.15 592.15 592.14 592.13 592.13 592.12 592.12 592.11		

16.00	DISCHG	2.17	2.14	2.11	2.09	2.07	2.06	2.03	1.99	1.93	1.89
16.00	ELEV	592.11	592.11	592.11	592.10	592.10	592.10	592.10	592.10	592.09	592.09
17.00	DISCHG	1.85	1.81	1.79	1.77	1.75	1.73	1.72	1.71	1.70	1.67
17.00	ELEV	592.09	592.08	592.08	592.08	592.08	592.08	592.08	592.07	592.07	592.07
18.00	DISCHG	1.61	1.57	1.53	1.49	1.46	1.44	1.42	1.41	1.39	1.38
18.00	ELEV	592.07	592.06	592.06	592.06	592.05	592.05	592.05	592.05	592.05	592.05
19.00	DISCHG	1.37	1.37	1.36	1.36	1.35	1.35	1.35	1.34	1.34	1.31
19.00	ELEV	592.05	592.05	592.05	592.05	592.05	592.05	592.05	592.05	592.04	592.04
20.00	DISCHG	1.26	1.22	1.18	1.15	1.12	1.10	1.09	1.07	1.06	1.05
20.00	ELEV	592.04	592.04	592.03	592.03	592.03	592.03	592.02	592.02	592.02	592.02
21.00	DISCHG	1.04	1.03	1.03	1.02	1.02	1.02	1.01	1.01	1.01	1.01
21.00	ELEV	592.02	592.02	592.02	592.02	592.02	592.02	592.02	592.02	592.02	592.02
22.00	DISCHG	1.01	1.01	1.01	1.01	1.01	1.01	1.00	1.00	1.00	1.00
22.00	ELEV	592.02	592.02	592.02	592.02	592.02	592.02	592.02	592.02	592.02	592.02
23.00	DISCHG	1.00	1.00	1.00	1.00	1.00	1.00	1.00	1.00	1.00	.97
23.00	ELEV	592.02	592.02	592.02	592.02	592.02	592.02	592.02	592.02	592.02	592.02
24.00	DISCHG	.93	.86	.78	.78	.78	.78	.77	.77	.77	.77
24.00	ELEV	592.01	592.01	592.00	591.98	591.97	591.96	591.94	591.93	591.92	591.90
25.00	DISCHG	.77	.77	.77	.76	.76	.76	.76	.76	.76	.75
25.00	ELEV	591.89	591.88	591.86	591.85	591.84	591.82	591.81	591.80	591.78	591.77
26.00	DISCHG	.75	.75	.75	.74	.74	.74	.74	.73	.73	.73
26.00	ELEV	591.75	591.73	591.72	591.70	591.69	591.68	591.66	591.65	591.63	591.62
27.00	DISCHG	.73	.72	.72	.72	.72	.71	.71	.71	.71	.70
27.00	ELEV	591.60	591.59	591.57	591.56	591.54	591.53	591.51	591.50	591.49	591.47
28.00	DISCHG	.70	.70	.70	.69	.69	.69	.68	.68	.68	.68
28.00	ELEV	591.46	591.44	591.43	591.42	591.40	591.39	591.37	591.36	591.35	591.33
29.00	DISCHG	.68	.67	.67	.67	.67	.66	.66	.66	.66	.65
29.00	ELEV	591.32	591.31	591.29	591.28	591.27	591.25	591.24	591.23	591.21	591.20

RUNOFF VOLUME ABOVE BASEFLOW = 2.95 WATERSHED INCHES, 53.60 CFS-HRS, 4.43 ACRE-FEET; BASEFLOW = .00 CFS

EXECUTIVE CONTROL OPERATION ENDCMP

COMPUTATIONS COMPLETED FOR PASS 3

RECORD ID

EXECUTIVE CONTROL OPERATION COMPUT

RECORD ID

+
+

FROM STRUCTURE 1 TO STRUCTURE 1

STARTING TIME = .00 RAIN DEPTH = 6.70 RAIN DURATION= 1.00 RAIN TABLE NO.= 2 ANT. MOIST. COND= 2
ALTERNATE NO.= 0 STORM NO.=99 MAIN TIME INCREMENT = .10 HOURS

OPERATION RUNOFF STRUCTURE 1

OUTPUT HYDROGRAPH= 4

AREA= .03 SQ MI INPUT RUNOFF CURVE= 90. TIME OF CONCENTRATION= .14 HOURS
INTERNAL HYDROGRAPH TIME INCREMENT= .0187 HOURS

PEAK TIME(HRS)	PEAK DISCHARGE(CFS)	PEAK ELEVATION(FEET)
11.97	125.00	(RUNOFF)
23.65	1.43	(RUNOFF)

RUNOFF VOLUME ABOVE BASEFLOW = 5.53 WATERSHED INCHES, 100.29 CFS-HRS, 8.29 ACRE-FEET; BASEFLOW = .00 CFS

OPERATION RESVOR STRUCTURE 1

INPUT HYDROGRAPH= 4 OUTPUT HYDROGRAPH= 5
SURFACE ELEVATION= 588.00

PEAK TIME(HRS)	PEAK DISCHARGE(CFS)	PEAK ELEVATION(FEET)
12.11	75.36	595.22

TIME(HRS)	DISCHG	FIRST HYDROGRAPH POINT = .00 HOURS	TIME INCREMENT = .10 HOURS	DRAINAGE AREA = .03 SQ.MI.
3.00	.00	.00	.00	.01
3.00	ELEV	588.00	588.00	588.02
4.00	.02	.02	.03	.04
4.00	ELEV	588.04	588.05	588.11
5.00	.06	.06	.07	.07
5.00	ELEV	588.15	588.17	588.27
6.00	.09	.09	.10	.11
6.00	ELEV	588.32	588.34	588.50
7.00	.14	.15	.16	.17
7.00	ELEV	588.59	588.62	588.81
8.00	.20	.21	.22	.23
8.00	ELEV	588.91	588.95	589.20
9.00	.25	.26	.27	.28
9.00	ELEV	589.33	589.38	589.73
10.00	.31	.32	.36	.41
10.00	ELEV	589.93	590.00	590.39
11.00	.58	.62	.65	.70
11.00	ELEV	590.86	591.00	591.99
12.00	59.21	75.24	64.29	40.44
12.00	ELEV	594.80	595.22	593.84
13.00	14.29	12.85	11.91	10.29
13.00	ELEV	593.04	592.96	592.70
14.00	6.86	6.46	6.10	5.78
14.00	ELEV	592.48	592.45	592.37

15.00	DISCHG	4.07	3.94	3.83	3.73	3.62	3.49	3.38	3.29	3.21	3.14
15.00	ELEV	592.26	592.25	592.24	592.24	592.23	592.22	592.21	592.20	592.19	592.19
16.00	DISCHG	3.09	3.05	3.01	2.98	2.96	2.93	2.90	2.83	2.75	2.69
16.00	ELEV	592.18	592.18	592.18	592.18	592.17	592.17	592.17	592.16	592.16	592.15
17.00	DISCHG	2.63	2.58	2.55	2.52	2.49	2.47	2.45	2.44	2.42	2.37
17.00	ELEV	592.15	592.14	592.14	592.14	592.14	592.13	592.13	592.13	592.13	592.13
18.00	DISCHG	2.30	2.23	2.17	2.12	2.08	2.05	2.02	2.00	1.98	1.97
18.00	ELEV	592.12	592.12	592.11	592.11	592.10	592.10	592.10	592.10	592.10	592.09
19.00	DISCHG	1.96	1.95	1.94	1.93	1.92	1.92	1.92	1.91	1.91	1.87
19.00	ELEV	592.09	592.09	592.09	592.09	592.09	592.09	592.09	592.09	592.09	592.09
20.00	DISCHG	1.80	1.74	1.68	1.64	1.60	1.57	1.54	1.52	1.51	1.49
20.00	ELEV	592.08	592.08	592.07	592.07	592.07	592.06	592.06	592.06	592.06	592.06
21.00	DISCHG	1.48	1.47	1.46	1.46	1.45	1.45	1.44	1.44	1.44	1.43
21.00	ELEV	592.06	592.06	592.05	592.05	592.05	592.05	592.05	592.05	592.05	592.05
22.00	DISCHG	1.43	1.43	1.43	1.43	1.43	1.43	1.43	1.43	1.43	1.43
22.00	ELEV	592.05	592.05	592.05	592.05	592.05	592.05	592.05	592.05	592.05	592.05
23.00	DISCHG	1.43	1.43	1.43	1.43	1.43	1.43	1.43	1.43	1.43	1.38
23.00	ELEV	592.05	592.05	592.05	592.05	592.05	592.05	592.05	592.05	592.05	592.05
24.00	DISCHG	1.32	1.21	1.05	.88	.78	.78	.78	.78	.77	.77
24.00	ELEV	592.04	592.03	592.02	592.01	591.99	591.98	591.97	591.95	591.94	591.93
25.00	DISCHG	.77	.77	.77	.77	.77	.76	.76	.76	.76	.76
25.00	ELEV	591.91	591.90	591.89	591.87	591.86	591.85	591.83	591.82	591.81	591.79
26.00	DISCHG	.76	.75	.75	.75	.75	.74	.74	.74	.74	.73
26.00	ELEV	591.78	591.76	591.75	591.73	591.72	591.70	591.69	591.67	591.66	591.64
27.00	DISCHG	.73	.73	.72	.72	.72	.71	.71	.71	.71	.71
27.00	ELEV	591.63	591.61	591.60	591.58	591.57	591.56	591.54	591.53	591.51	591.50
28.00	DISCHG	.70	.70	.70	.70	.69	.69	.69	.69	.69	.68
28.00	ELEV	591.48	591.47	591.46	591.44	591.43	591.41	591.40	591.39	591.37	591.36
29.00	DISCHG	.68	.68	.68	.67	.67	.67	.66	.66	.66	.66
29.00	ELEV	591.34	591.33	591.32	591.30	591.29	591.28	591.26	591.25	591.24	591.22

RUNOFF VOLUME ABOVE BASEFLOW = 4.80 WATERSHED INCHES, 87.09 CFS-HRS, 7.20 ACRE-FEET; BASEFLOW = .00 CFS

EXECUTIVE CONTROL OPERATION ENDCMP

RECORD ID

COMPUTATIONS COMPLETED FOR PASS 4

EXECUTIVE CONTROL OPERATION ENDJOB

RECORD ID

SUMMARY TABLE 1 - SELECTED RESULTS OF STANDARD AND EXECUTIVE CONTROL INSTRUCTIONS IN THE ORDER PERFORMED
(A STAR(*) AFTER THE PEAK DISCHARGE TIME AND RATE (CFS) VALUES INDICATES A FLAT TOP HYDROGRAPH
A QUESTION MARK(?) INDICATES A HYDROGRAPH WITH PEAK AS LAST POINT.)

SECTION/ STRUCTURE ID	STANDARD CONTROL OPERATION	DRAINAGE AREA (SQ MI)	RAIN TABLE #	ANTEC MOIST COND	MAIN TIME INCREM (HR)	PRECIPITATION			RUNOFF AMOUNT (IN)	PEAK DISCHARGE				
						BEGIN (HR)	AMOUNT (IN)	DURATION (HR)		ELEVATION (FT)	TIME (HR)	RATE (CFS)	RATE (CSM)	
ALTERNATE 0 STORM 1														
+	STRUCTURE 1	RUNOFF	.03	2	2	.10	.0	2.50	24.00	1.53	---	11.98	37.12	1319.9
	STRUCTURE 1	RESVOR	.03	2	2	.10	.0	2.50	24.00	.88	592.09	13.60	1.87	66.6
ALTERNATE 0 STORM 2														
+	STRUCTURE 1	RUNOFF	.03	2	2	.10	.0	3.00	24.00	1.98	---	11.98	47.59	1692.2
	STRUCTURE 1	RESVOR	.03	2	2	.10	.0	3.00	24.00	1.29	592.40	12.44	5.83	207.2
ALTERNATE 0 STORM 10														
+	STRUCTURE 1	RUNOFF	.03	2	2	.10	.0	4.80	24.00	3.68	---	11.98	85.43	3037.5
	STRUCTURE 1	RESVOR	.03	2	2	.10	.0	4.80	24.00	2.95	593.99	12.15	35.89	1276.0
ALTERNATE 0 STORM 99														
+	STRUCTURE 1	RUNOFF	.03	2	2	.10	.0	6.70	24.00	5.53	---	11.97	125.00	4444.4
	STRUCTURE 1	RESVOR	.03	2	2	.10	.0	6.70	24.00	4.80	595.22	12.11	75.36	2679.5

TR20 XEQ 04-25-06 08:37
REV PC 09/83(.2)

NEW HAVEN
SWM POND '2'

File:TR20\1008A-P2.T20

JOB 1 SUMMARY
PAGE 10

SUMMARY TABLE 3 - DISCHARGE (CFS) AT XSECTIONS AND STRUCTURES FOR ALL STORMS AND ALTERNATES

XSECTION/ STRUCTURE ID	DRAINAGE AREA (SQ MI)	STORM NUMBERS.....			
		1	2	10	99
0 STRUCTURE 1	.03				
<hr/>					
ALTERNATE 0		1.87	5.83	35.89	75.36

END OF 1 JOBS IN THIS RUN